



Installer manual  
**JÄSPI Inverter Nordic™**

8, 12, 16, 20

Air/water heat pump



# Table of Contents

<b>1 Important information</b>	<b>4</b>	<b>9 Alarm list</b>	<b>40</b>
Safety information	4		
<b>2 Delivery and handling</b>	<b>9</b>	<b>10 Accessories</b>	<b>42</b>
Transport and storage	9		
Assembly	9	<b>11 Technical data</b>	<b>43</b>
Condensation	11	Dimensions	43
Installation area	13	Sound pressure levels	44
Supplied components	13	Technical specifications	45
Removing the side cover and top panel	14	Working area	49
		Heating	51
		Cooling	53
		Energy labelling	54
		Electrical circuit diagram	59
<b>3 The heat pump design</b>	<b>15</b>	<b>Item register</b>	<b>67</b>
General	15		
Distribution box	19		
<b>4 Pipe connections</b>	<b>20</b>		
General	20		
Pipe coupling heating medium circuit	20		
Pressure drop, heating medium side	20		
Heat insulation	20		
Installing flex hoses	21		
<b>5 Electrical connections</b>	<b>22</b>		
General	22		
	22		
Accessibility, electrical connection	23		
Configuration using dip switch	24		
Connections	25		
Optional connections	28		
Connecting accessories	31		
<b>6 Commissioning and adjusting</b>	<b>32</b>		
Preparations	32		
Filling and venting the heating medium system	32		
Start-up and inspection	32		
Readjusting, heating medium side	32		
Adjustment, charge flow	33		
<b>7 Control - Introduction</b>	<b>34</b>		
General	34		
LED status	34		
Master control	34		
Control conditions	35		
Control - Heat pump EB101	36		
<b>8 Disturbances in comfort</b>	<b>37</b>		
Troubleshooting	37		

# 1 Important information

## Safety information

This manual describes installation and service procedures for implementation by specialists.

This appliance can be used by children aged from 8 years and above and persons with reduced physical, sensory or mental capabilities or lack of experience and knowledge if they have been given supervision or instruction concerning use of the appliance in a safe way and understand the hazards involved. The product is intended for use by experts or trained users in shops, hotels, light industry, farming and similar environments.

Children must be instructed/supervised to ensure that they do not play with the appliance.

Do not allow children to clean or maintain the appliance unsupervised.

This is an original manual. It may not be translated without the approval of Kaukora.

We reserve the right to make design modifications without prior notice.

## Balance temperature

The balance temperature is the outdoor temperature when the heat pump's stated output is equal to the building's output requirement. This means that the heat pump covers the whole building's output requirement down to this temperature.

## Compressor heater

JÄSPI Inverter Nordic is equipped with two JÄSPI compressor heaters that heat the compressor before start-up and when the compressor is cold.

### NOTE

The compressor heater must have been active for approx. 3 hours before the first start, see section "Start-up and inspection" on page 32.

## Symbols

### NOTE

This symbol indicates danger to machine or person.



### Caution

This symbol indicates important information about what you should observe when maintaining your installation.



### TIP

This symbol indicates tips on how to facilitate using the product.

## Marking

The CE marking means that Kaukora ensures that the product meets all regulations that are placed on it based on relevant EU directives. The CE mark is obligatory for most products sold in the EU, regardless where they are made.

## Serial number

The serial number can be found at the top left on the rear cover and at the bottom on the side.

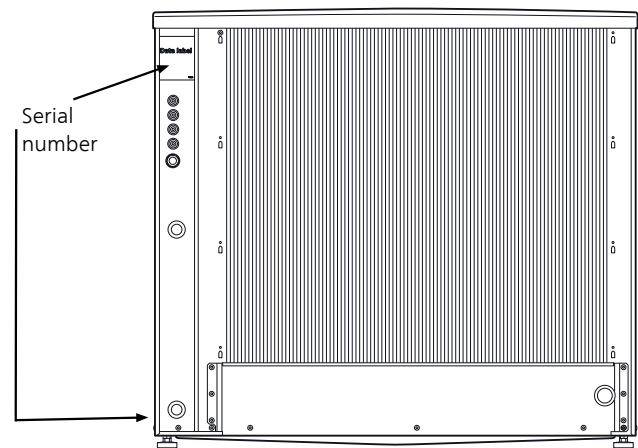

### Caution

You need the product's (14 digit) serial number for servicing and support.

## Recovery



Leave the disposal of the packaging to the installer who installed the product or to special waste stations.

Do not dispose of used products with normal household waste. It must be disposed of at a special waste station or dealer who provides this type of service.

Improper disposal of the product by the user results in administrative penalties in accordance with current legislation.

## Environmental information

The equipment contains R410A, a fluorinated greenhouse gas with a GWP value (Global Warming Potential) of 2088. Do not release R410A into the atmosphere.

## **Country specific information**

### ***Installer manual***

This installer manual must be left with the customer.

## Safety precautions

### Caution

#### **Install the system in full accordance with this installation manual.**

Incorrect installation can cause bursts, personal injury, water leaks, refrigerant leaks, electric shocks and fire.

**Observe the measurement values before working on the cooling system, especially when installing in small rooms, so that the limit for the refrigerant's density is not exceeded.**  
Consult an expert to interpret the measurement values. If the refrigerant density exceeds the limit, lack of oxygen can occur in the event of any leak, which can cause serious accidents.

#### **Use original accessories and the stated components for the installation.**

If parts other than those stated by us are used, water leaks, electric shocks, fire and personal injury may occur as the unit may not work properly.

#### **Ventilate the working area well – refrigerant leakage may occur during service work.**

If the refrigerant comes into contact with naked flames, poisonous gas is created.

#### **Install the unit in a location with good support.**

Unsuitable installation locations can cause the unit to fall and cause material damage and personal injury. Installation without sufficient support can also cause vibrations and noise.

#### **Ensure that the unit is stable when installed, so that it can withstand earthquakes and strong winds.**

Unsuitable installation locations can cause the unit to fall and cause material damage and personal injury.

#### **The electrical installation must be carried out by a qualified electrician and the system must be connected as a separate circuit.**

Power supply with insufficient capacity and incorrect function can cause electric shocks and fire.

#### **Use the stated cables for the electrical connection, tighten the cables securely in the terminal blocks and relieve the wiring correctly to prevent overloading the terminal blocks.**

Loose connections or cable mountings can cause abnormal heat production or fire.

#### **Check, after completed installation or service, that no refrigerant leaks from the system in gas form.**

If refrigerant gas leaks into the house and comes into contact with an aerotemp, an oven or other hot surface, poisonous gases are produced.

#### **Switch off the compressor before opening/breaching the refrigerant circuit.**

If the refrigerant circuit is breached /opened whilst the compressor is running, air can enter the process circuit. This can cause unusually high pressure in the process circuit, which can cause bursts and personal injury.

#### **Switch off the power supply in the event of a service or inspection.**

If the power supply is not shut off, there is a risk of electric shocks and damage due to the rotating fan.

#### **Do not run the unit with removed panels or protection.**

Touching rotating equipment, hot surfaces or high voltage parts can cause personal injury due to entrapment, burns or electric shocks.

#### **Cut the power before starting electrical work.**

Failure to cut the power can cause electric shocks, damage and incorrect function of the equipment.

### Care

#### **Carry out the electrical installation with care.**

Do not connect the ground lead to the gas line, water line, lightning conductor or telephone line's ground lead. Incorrect grounding can cause unit faults such as electric shocks due to short-circuiting.

#### **Use main switch with sufficient breaking capacity.**

If the switch does not have sufficient breaking capacity, malfunctions and fire can occur.

#### **Always use a fuse with the correct rating in the locations where fuses are to be used.**

Connecting the unit with copper wire or other metal thread can cause unit breakdown and fire.

#### **Cables must be routed so that they are not damaged by metal edges or trapped by panels.**

Incorrect installation can cause electric shocks, heat generation and fire.

#### **Do not install the unit in close proximity to locations where leakage of combustible gases can occur.**

If leaking gases collect around the unit, fire may occur.

#### **Do not install the unit where corrosive gas (for example nitrous fumes) or combustible gas or steam (for example thinner and petroleum gases) can build up or collect, or where volatile combustible substances are handled.**

Corrosive gas can cause corrosion to the heat exchanger, breaks in plastic parts etc. and combustible gas or steam can cause fire.

#### **Do not use the unit where water splashes may occur, for example in laundries.**

The indoor section is not waterproof and electric shocks and fire can therefore occur.

#### **Do not use the unit for specialist purposes such as for storing food, cooling precision instruments, freeze-conservation of animals, plants or art.**

This can damage the items.

#### **Do not install and use the system close to equipment that generates electromagnetic fields or high frequency harmonics.**

Equipment such as inverters, standby sets, medical high frequency equipment and telecommunications equipment can affect the unit and cause malfunctions and breakdowns. The unit can also affect medical equipment and telecommunications equipment, so that it functions incorrectly or not at all.

#### **Do not install the outdoor unit in the locations stated below.**

- Locations where leakage of combustible gas can occur.
- Locations where carbon fibre, metal powder or other powder that can enter the air.
- Locations where substances that can affect the unit, for example, sulphide gas, chlorine, acid or alkaline substances can occur.
- Locations with direct exposure to oil mist or steam.
- Vehicles and ships.
- Locations where machines that generate high frequency harmonics are used.
- Locations where cosmetic or special sprays are often used.
- Locations that can be subjected to direct salty atmospheres. In this case, the outdoor unit must be protected against direct intakes of salty air.
- Locations where large amounts of snow occur.
- Locations where the system is exposed to chimney smoke.

#### **If the bottom frame of the outdoor section is corroded, or in any other way damaged, due to long periods of operation, it must not be used.**

Using an old and damaged frame can cause the unit to fall and cause personal injury.

#### **If soldering near the unit, ensure that solder residue does not damage the drip tray.**

If solder residue enters the unit during soldering, small holes can appear in the tray resulting in water leakage. To prevent damage, keep the indoor unit in its packing or cover it.

#### **Do not allow the drainage pipe to exit into channels where poisonous gases, containing sulphides for example, can occur.**

If the pipe exits into such a channel, any poisonous gases will flow into the room and seriously affect the user's health and safety.

#### **Insulate the unit's connection pipes so that the ambient air moisture does not condense on them.**

Insufficient insulation can cause condensation, which can lead to moisture damage on the roof, floor, furniture and valuable personal property.

#### **Do not install the outdoor unit in a location where insects and small animals can inhabit.**

Insects and small animals can enter the electronic parts and cause damage and fire. Instruct the user to keep the surrounding equipment clean.

**Take care when carrying the unit by hand.**

If the unit weighs more than 20 kg, it must be carried by two people. Use gloves to minimize the risk of cuts.

**Dispose of any packaging material correctly.**

Any remaining packaging material can cause personal injury as it may contain nails and wood.

**Do not touch any buttons with wet hands.**

This can cause electric shocks.

**Do not touch any refrigerant pipes with your hands when the system is in operation.**

During operation the pipes become extremely hot or extremely cold, depending on the method of operation. This can cause burn injuries or frost injuries.

**Do not shut off the power supply immediately after operation has started.**

Wait at least 5 minutes, otherwise there is a risk of water leakage or breakdown.

**Do not control the system with the main switch.**

This can cause fire or water leakage. In addition, the fan can start unexpectedly, which can cause personal injury.

***Especially for units intended for R410A***

- Do not use other refrigerants than R410A. R410A means that the pressure is about 1.6 times as high as conventional refrigerants.
- Do not use charging bottles. These types of bottles change the composition of the refrigerant, which makes the performance of the system worse.
- When filling refrigerant, the refrigerant must always leave the bottle in liquid form.

## Inspection of the installation

Current regulations require the heating installation to be inspected before it is commissioned. The inspection must be carried out by a suitably qualified person. Fill in the page for information about installation data in the User manual.

✓	Description	Notes	Signature	Date
	Heating medium (page 20)			
	System flushed			
	System vented			
	Particle filter			
	Shut-off and drain valve			
	Charge flow set			
	Electricity (page 22)			
	Fuses property			
	Safety breaker			
	Earth circuit-breaker			
	Heating cable type/effect			
	Fuse size, heating cable (F3)			
	Communication cable connected			
	JÄSPI Inverter Nordic addressed (only when cascade connection)			
	Connections			
	Main voltage			
	Phase voltage			
	Miscellaneous			
	Condensation water pipe			
	Insulation condensation water pipe, thickness (if KVR 10 is not used)			



### NOTE

Check the connections, main voltage and phase voltage before the machine is started, to prevent damage to the heat pump electronics.



## 2 Delivery and handling

### Transport and storage

JÄSPI Inverter Nordic must be transported and stored vertically.



#### NOTE

Ensure that the heat pump cannot fall over during transport.

Ensure that the heat pump cannot be damaged during transportation.

### Assembly

- Place JÄSPI Inverter Nordic outdoors on a solid level base that can take the weight, preferably a concrete foundation. If concrete slabs are used they must rest on asphalt or shingle.
- The lower edge of the evaporator must be at the level of the average local snow depth. The concrete foundation or concrete plinths must therefore be at least 70 mm high.
- JÄSPI Inverter Nordic should not be positioned next to noise sensitive walls, for example, next to a bedroom.
- Also ensure that the placement does not inconvenience the neighbours.
- JÄSPI Inverter Nordic must not be placed so that recirculation of the outdoor air can occur. This causes lower output and impaired efficiency.
- The evaporator must be sheltered from direct wind / , which negatively affects the defrosting function. Place JÄSPI Inverter Nordic protected from wind / against the evaporator.
- Some water may drip from the drainage hole below JÄSPI Inverter Nordic. Make sure that water can run off by selecting a suitable material underneath JÄSPI Inverter Nordic (see page 11).
- Care must be exercised so that the heat pump is not scratched during installation.

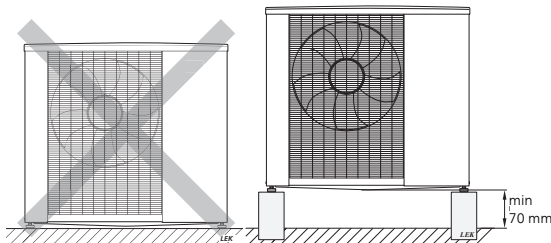

Do not place JÄSPI Inverter Nordic directly on the lawn or other non solid surface.

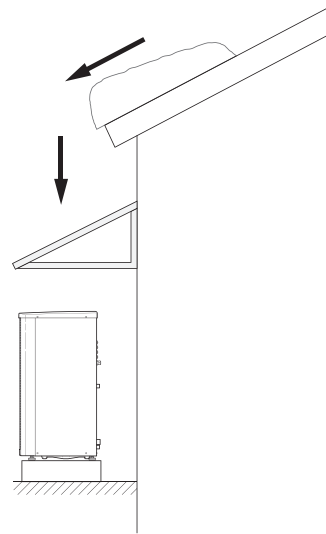

If there is a risk of snow slip from roof, a protective roof or cover must be erected to protect the heat pump, pipes and wiring.

## Lift from the street to the set up location

If the base allows, the simplest thing is to use a pallet truck to move the JÄSPI Inverter Nordic to the set up location.



### NOTE

The centre of gravity is offset to one side (see print on the packaging).

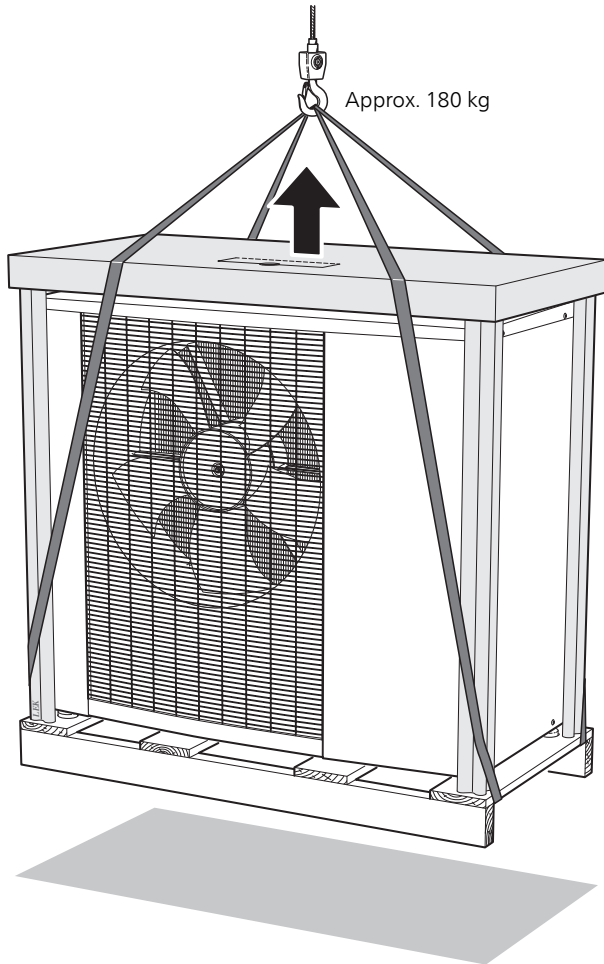

If JÄSPI Inverter Nordic needs to be transported across soft ground, such as a lawn, we recommend that a crane is used that can lift the unit to the installation location. When JÄSPI Inverter Nordic is lifted with a crane, the packaging must be undisturbed, see the illustration above.

If a crane vehicle cannot be used the JÄSPI Inverter Nordic can be transported on an extended sack truck. JÄSPI Inverter Nordic must be taken from its heaviest side and two people are required to lift JÄSPI Inverter Nordic.

## Lift from the pallet to final positioning

Before lifting remove the packaging and the securing strap to the pallet.

Place lifting straps around each machine foot. Lifting from the pallet to the base requires four persons, one for each lifting strap.

## Scrapping

When scrapping, the product is removed in reverse order. Lift by the bottom panel instead of a pallet!

## Condensation

The condensation water trough collects and leads away most of the condensation water from the heat pump.

**NOTE**

- It is important to the heat pump function that condensation water is led away and that the drain for the condensation water run off is not positioned so that it can cause damage to the house.

**NOTE**

- Pipe with heating cable for draining the condensation water trough is not included.

**NOTE**

- To ensure this function the accessory KVR 10 should be used.

**NOTE**

- Condensation runoff should be checked regularly, especially during the autumn. Clean if necessary.

**NOTE**

- The electrical installation and wiring must be carried out under the supervision of an authorised electrician.

- The condensation water (up to 50 litres/24 hrs) that collects in the trough should be routed away by a pipe to an appropriate drain, it is recommended that the shortest outdoor stretch possible is used.
- The section of the pipe that can be affected by frost must be heated by the heating cable to prevent freezing.
- Route the pipe downward from JÄSPI Inverter Nordic.
- The outlet of the condensation water pipe must be at a depth that is frost free or alternatively indoors (with reservation for local ordinances and regulations).
- Use a water trap for installations where air circulation may occur in the condensation water pipe.
- The insulation must seal against the bottom of the condensation water trough.

## Recommended alternative for leading off condensation water

### Stone caisson

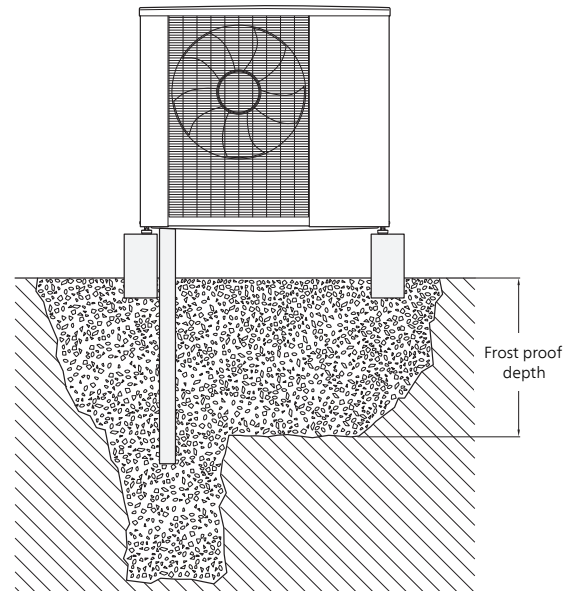

If the house has a cellar the stone caisson must be positioned so that condensation water does not affect the house. Otherwise the stone caisson can be positioned directly under the heat pump.

The outlet of the condensation water pipe must be at frost free depth.

### Drain indoors

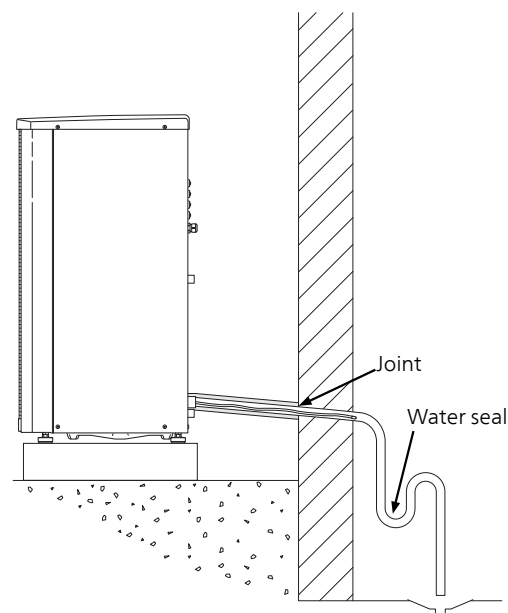

The condensation water is lead to an indoor drain (subject to local rules and regulations).

Route the pipe downward from JÄSPI Inverter Nordic.

The condensation water pipe must have a water seal to prevent air circulation in the pipe.

KVR 10 spliced as illustrated. Pipe routing inside house not included.

### **Gutter drainage**

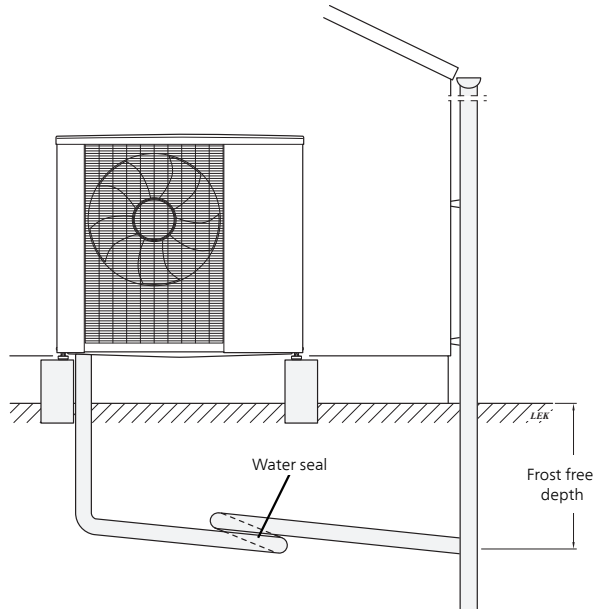

The outlet of the condensation water pipe must be at frost free depth.

Route the pipe downward from JÄSPI Inverter Nordic.

The condensation water pipe must have a water seal to prevent air circulation in the pipe.



#### **Caution**

If none of the recommended alternatives is used good lead off of condensation water must be assured.

## Installation area

The distance between JÄSPI Inverter Nordic and the house wall must be at least 350 mm. Clearance above JÄSPI Inverter Nordic should be at least 1,000 mm. However, free space in front must be 1,000mm for future servicing.

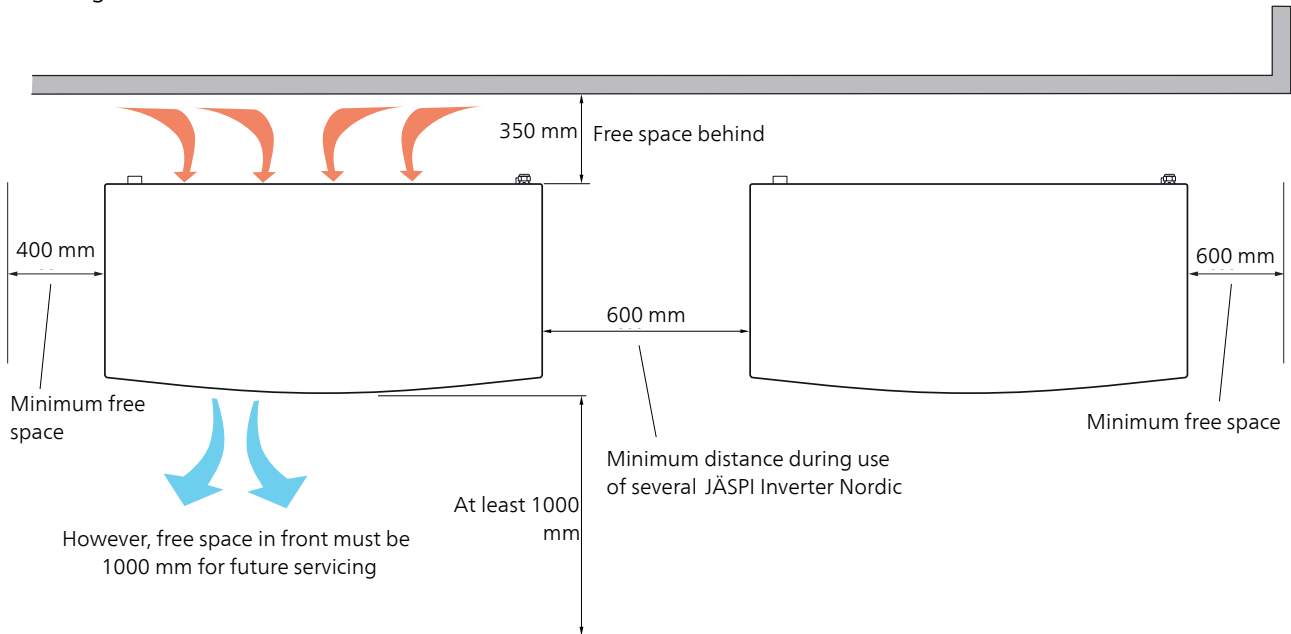

## Supplied components

### JÄSPI Inverter Nordic-8, JÄSPI Inverter Nordic-12

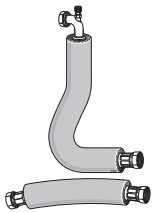

2 x flexible pipes (DN25, G1") with 4 x gaskets.

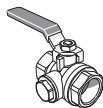

Shut off valve with filter (G1").

### JÄSPI Inverter Nordic-16, JÄSPI Inverter Nordic-20

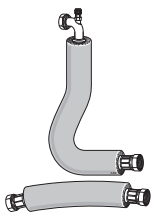

2 x flexible pipes (DN25, G1 1/4") with 4 x gaskets.



Shut off valve with filter (G1 1/4").

## Removing the side cover and top panel

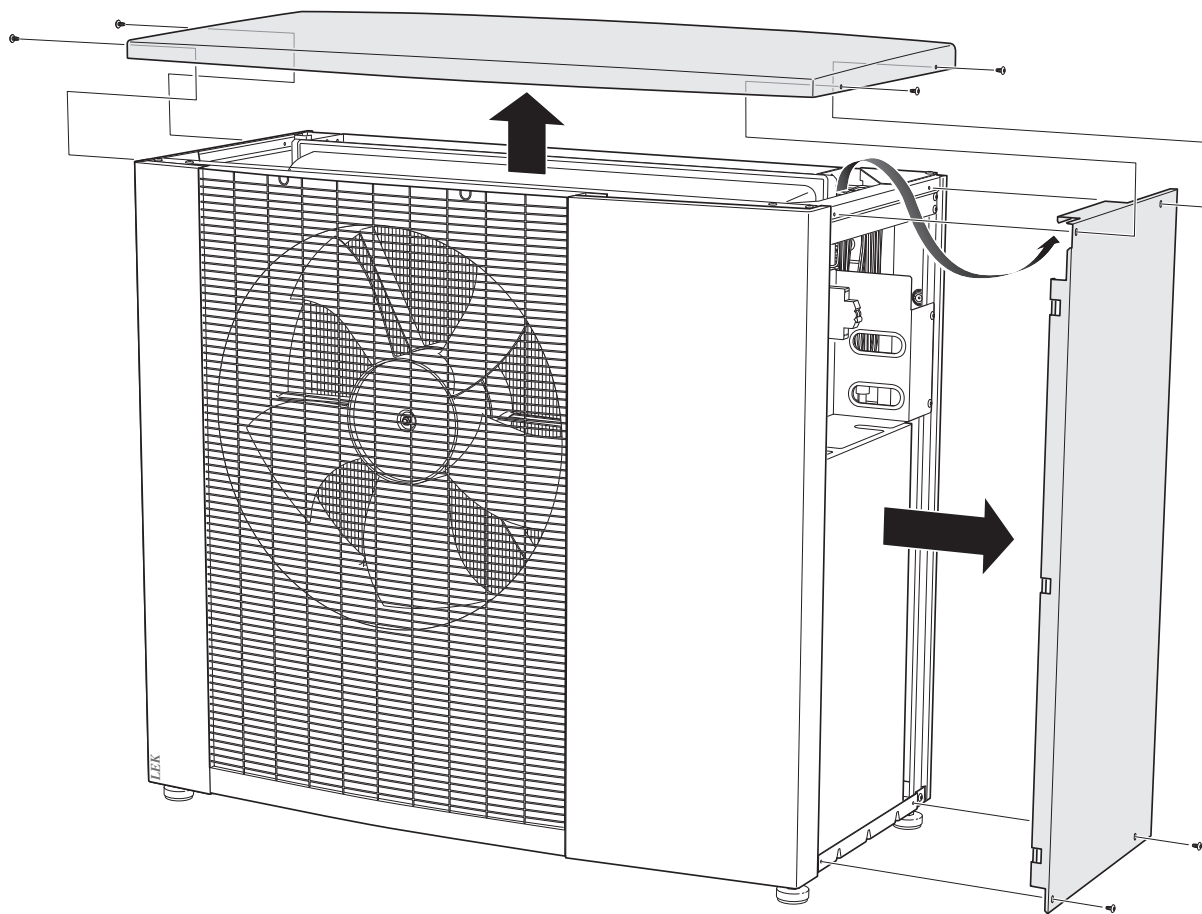

# 3 The heat pump design

## General

JÄSPI Inverter Nordic (1x230V)

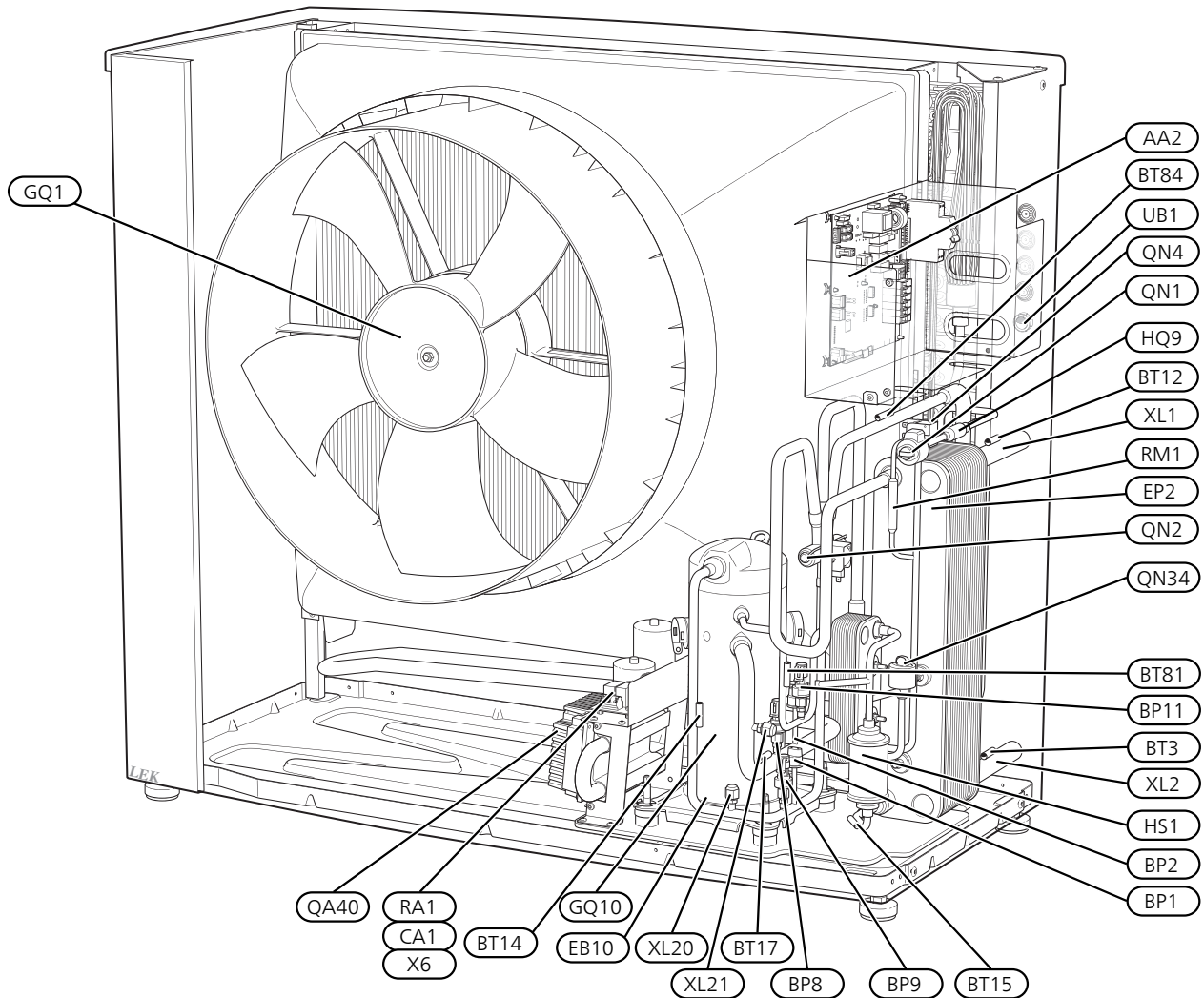

### JÄSPI Inverter Nordic (3x400V)

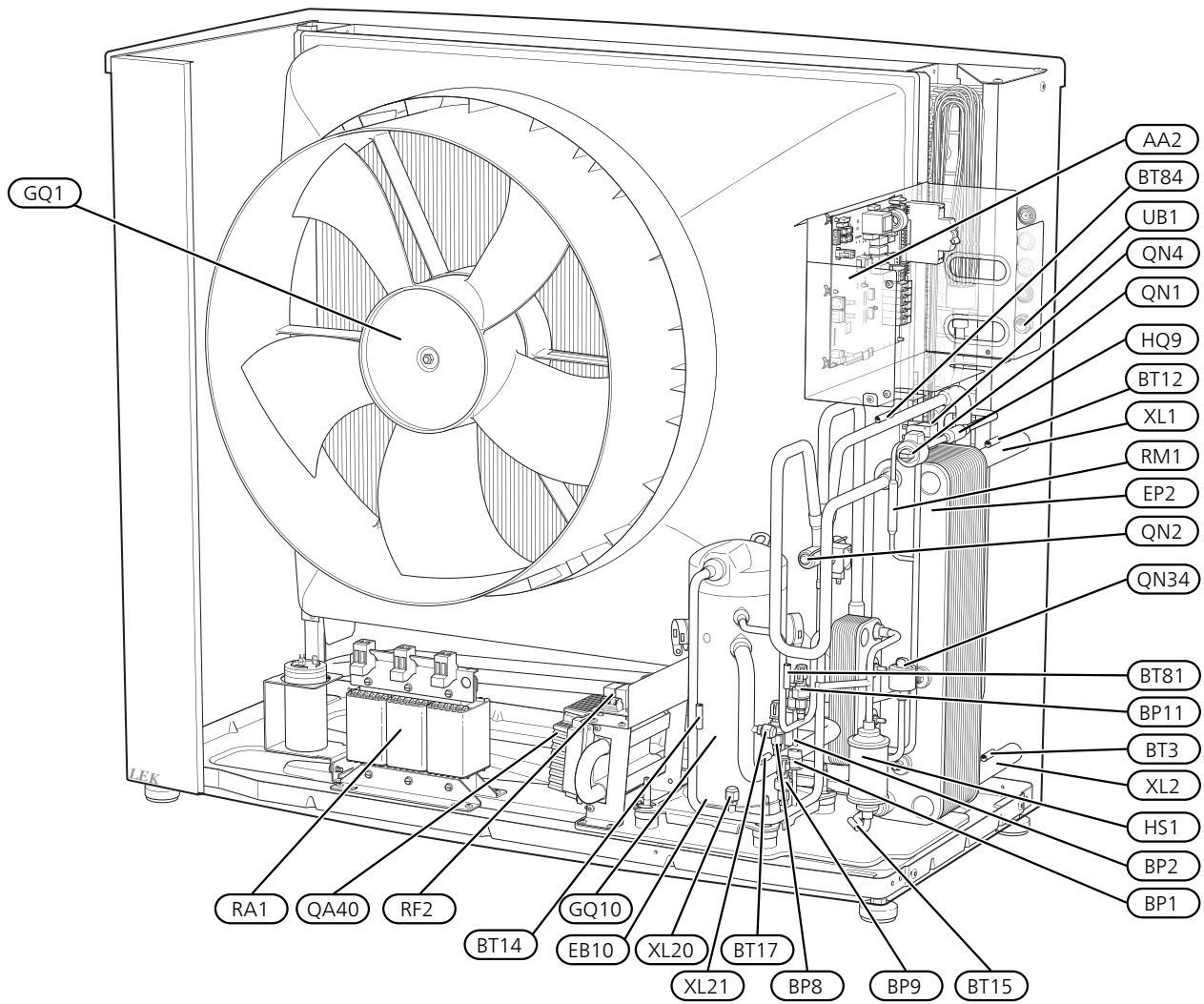



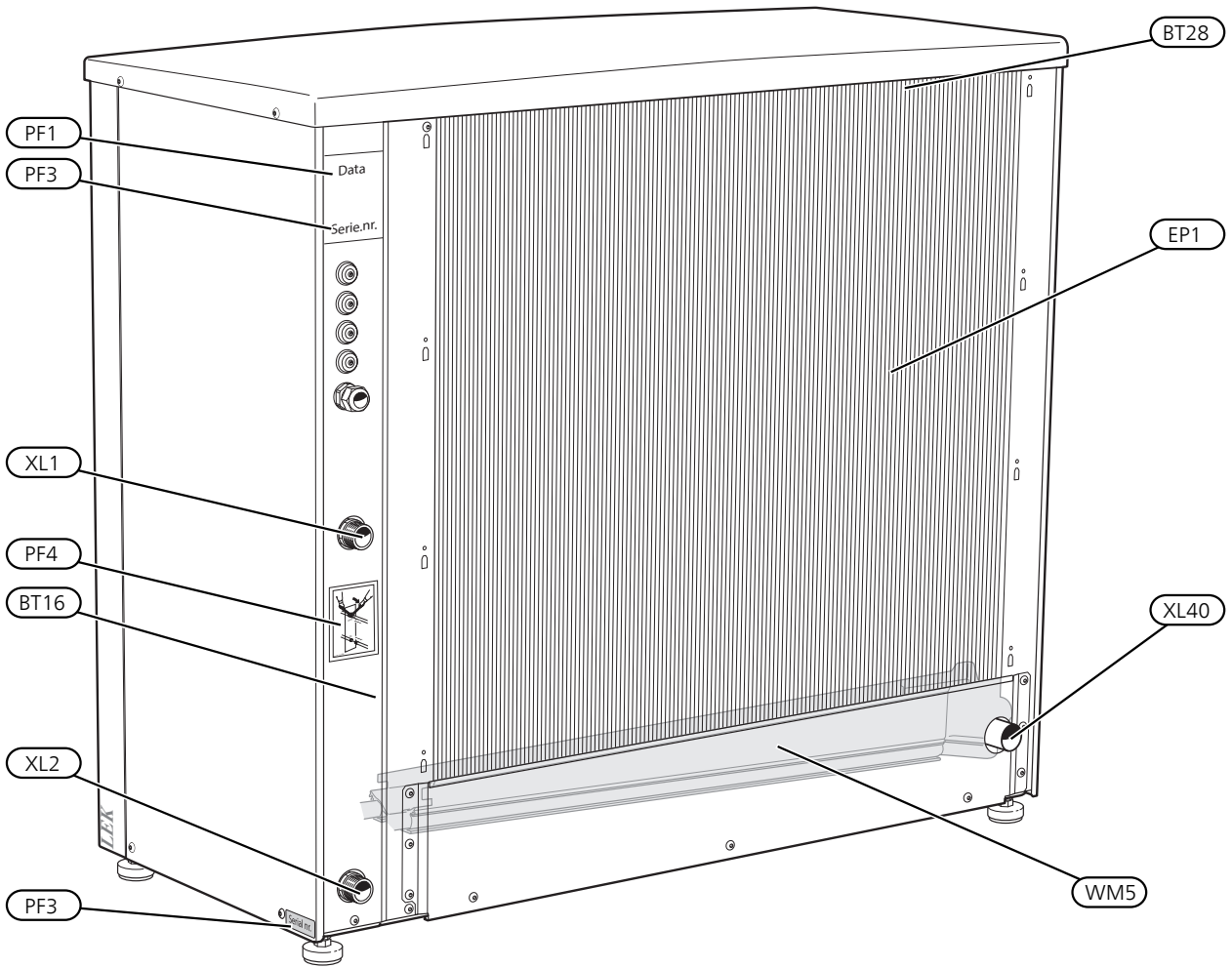

### **Pipe connections**

XL1	Connection, heating medium out of JÄSPI Inverter Nordic
XL2	Connection, heating medium in to JÄSPI Inverter Nordic,
XL20	Service connection, high pressure
XL21	Service connection, low pressure
XL40	Connection, drain condensation water trough

### **Sensors etc.**

BP1	High pressure pressostat
BP2	Low pressure pressostat
BP8	Low pressure transmitter
BP9	High pressure sensor
BP11	Pressure sensor, injection
BT3	Temperature sensor, return
BT12	Temperature sensor, condenser supply line
BT14	Temperature sensor, hot gas
BT15	Temperature sensor, fluid pipe
BT16	Temperature sensor, evaporator
BT17	Temperature sensor, suction gas
BT28	Temperature sensor, ambient
BT81	Temperature sensor, injection, EVI compressor
BT84	Temperature sensor, suction gas evaporator

### **Electrical components**

AA2	Base card
CA1	Capacitor (1x230V)
EB10	Compressor heater
GQ1	Fan
QA40	Inverter
RA1	Harmonic filter (3x400V)
RA1	Choke (1x230V)
RF2	EMC filter (3x400V)
X6	Terminal block (1x230V)

### **Cooling components**

EP1	Evaporator
EP2	Condenser
GQ10	Compressor
HQ9	Particle filter
HS1	Drying filter
QN1	Expansion valve
QN4	Bypass valve
QN2	4-way valve
QN34	Expansion valve, subcooling
RM1	Non-return valve

### **Miscellaneous**

PF1	Type plate
PF3	Serial number
PF4	Sign, pipe connections
UB1	Cable gland, incoming supply
WM5	Condensation water trough

Designations in component locations according to standard IEC 81346-1 and 81346-2.

## Distribution box

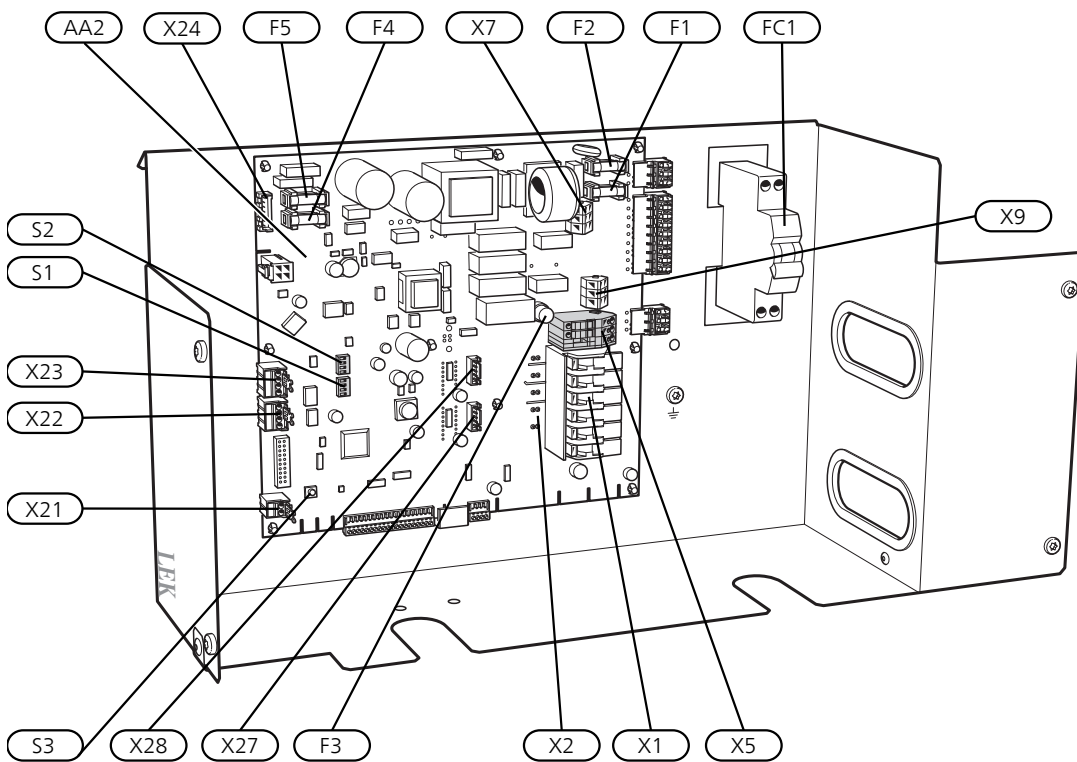

### Electrical components

AA2 Base card

- X1 Terminal block, incoming supply
- X2 Terminal block, compressor supply
- X5 Terminal block, external control voltage
- X7 Terminal block, 230V~
- X9 Terminal block, connection KVR
- X21 Terminal block, Compressor blocking, Tariff
- X22 Terminal block, communications
- X23 Terminal block, communications
- X24 Terminal block, fan
- X27 Terminal block, expansion valve QN1
- X28 Terminal block, subcooling QN34

- F1 Fuse, operating 230V~
- F2 Fuse, operating 230V~
- F3 Fuse for external heating cable KVR
- F4 Fuse, fan
- F5 Fuse, fan
- FC1 Miniature circuit breaker (Replaced with automatic protection (FB1) when installing accessory KVR 10.)

- S1 DIP switch, addressing heat pump during multi operation
- S2 DIP switch, different options
- S3 Reset button

Designations in component locations according to standard IEC 81346-1 and 81346-2.

# 4 Pipe connections

## General

Pipe installation must be carried out in accordance with current norms and directives.

JÄSPI Inverter Nordic can only operate up to a return temperature of about 55 °C and an outgoing temperature of about 65 °C from the heat pump.

JÄSPI Inverter Nordic is not equipped with external shut off valves on the water side; these must be installed to facilitate any future servicing. The return temperature is limited by the return line sensor.

## Water volumes

Depending on the size of JÄSPI Inverter Nordic, an available water volume is required to prevent short operating times and to enable defrosting. For optimal operation of JÄSPI Inverter Nordic, a minimum available water volume of 10 litres times the size number is recommended. E.g. JÄSPI Inverter Nordic-12: 10 litres x 12 = 120 litres.



### NOTE

The pipe work must be flushed before the heat pump is connected, so that any contaminants do not damage the components.

## Pipe coupling heating medium circuit

- The heat pump must be vented by the upper connection (XL1) using the venting nipple on the enclosed flexible hose.
- Install the enclosed particle filter before the inlet, i.e. the lower connection (XL2) on JÄSPI Inverter Nordic.
- All outdoor pipes must be thermally insulated with at least 19 mm thick pipe insulation.
- Install shutoff and drain valves so that JÄSPI Inverter Nordic can be emptied in the event of prolonged power failures.
- The supplied flexible hoses act as vibration dampers. The flexible pipes are fitted so an elbow is created, thus acting as vibration damping.

## Charge pump

The charge pump (not included in the product) is powered and controlled from the indoor module/control module. It has a built-in anti-freezing function and must therefore not be switched off when there is a risk of freezing.

At temperatures below +2 °C the charge pump runs periodically, to prevent the water from freezing in the charge circuit. The function also protects against excess temperatures in the charge circuit.

## Pressure drop, heating medium side

JÄSPI Inverter Nordic-8, -12, -16, -20

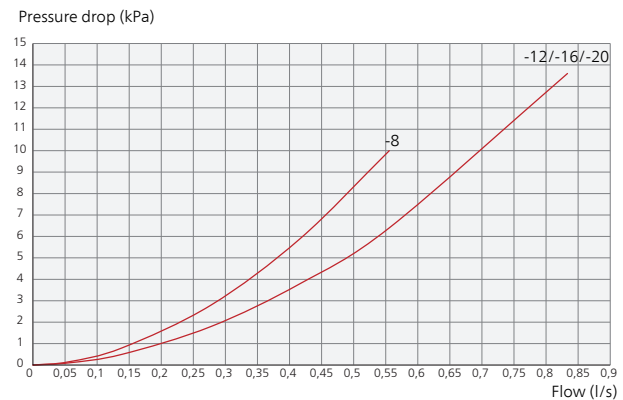

## Heat insulation

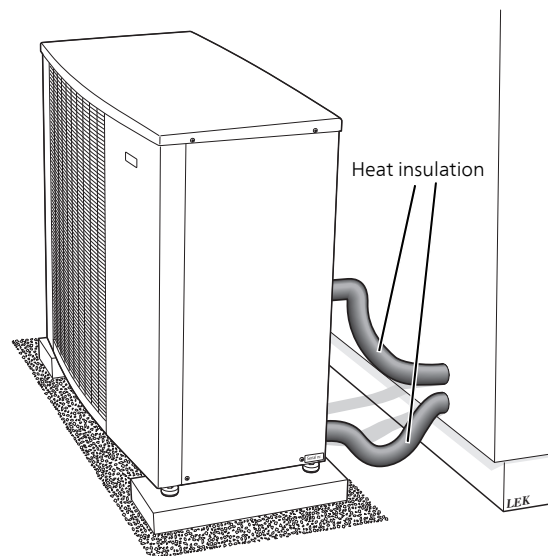

## Installing flex hoses

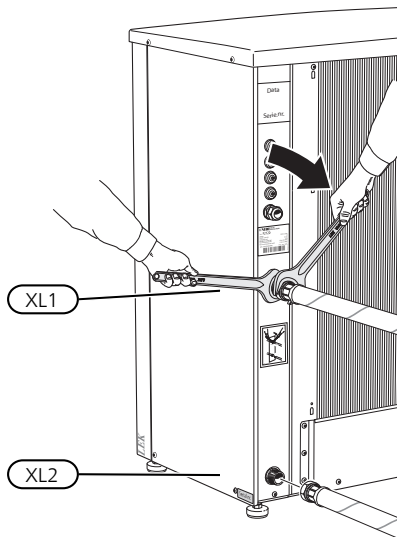

# 5 Electrical connections

## General

- The heat pump must not be connected without the permission of the electricity supplier and must be connected under the supervision of a qualified electrician.
- If JÄSPI Inverter Nordic is fused with a miniature circuit breaker, it must have at least motor characteristic "C". For MCB size see "Technical Specifications".
- JÄSPI Inverter Nordic does not include an omnipolar circuit breaker on the incoming power supply. The heat pump's supply cable must be connected to a circuit breaker with at least a 3 mm breaking gap. When the building is equipped with an earth-fault breaker, the heat pump should be equipped with a separate one. The earth-fault breaker should have a nominal tripping current of no more than 30 mA. Incoming supply must be 400V 3N~ 50Hz via electrical distribution units with fuses.  
For 230V~ 50Hz, the incoming supply must be 230V~ 50Hz via distribution box with fuses.
- If an insulation test is to be carried out in the building, disconnect the heat pump.
- If the control is to be supplied separately from other components in the heat pump (e.g. for tariff connection), a separate operating cable must be connected to terminal block (X5).
- The routing of cables for heavy current and signals should be made out through the cable glands on the heat pump's right-hand side, seen from the front.

- The communication cable must be a three core, screened cable and be connected between JÄSPI Inverter Nordic terminal block X22 and the indoor module/control module.
- Connect the charge pump to the indoor module/control module. See where the charge pump must be connected in the installation manual for your indoor module/control module.



### NOTE

Electrical installation and service must be carried out under the supervision of a qualified electrician. Cut the current with the circuit breaker before carrying out any servicing. Electrical installation and wiring must be carried out in accordance with the stipulations in force.



### NOTE

Check the connections, main voltage and phase voltage before the machine is started, to prevent damage to the air/water heat pump electronics.



### NOTE

The live external control must be taken into consideration when connecting.



### NOTE

If the supply cable is damaged, only Kaukora, its service representative or similar authorised person may replace it to prevent any danger and damage.

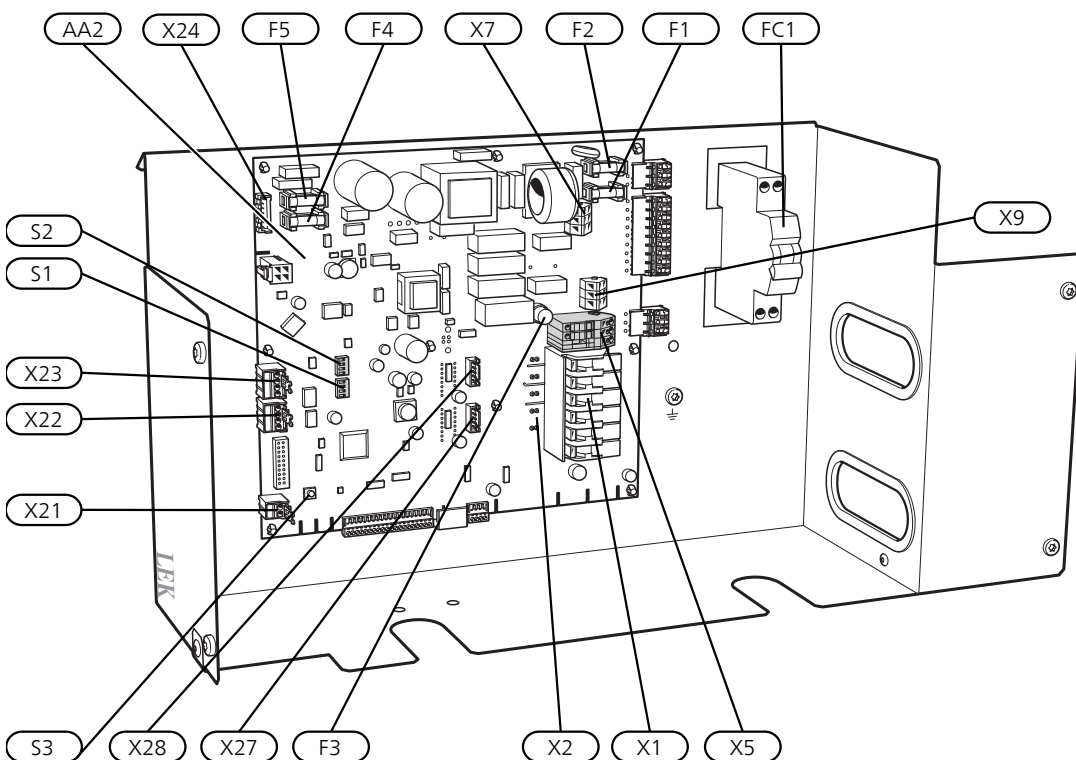

## Accessibility, electrical connection

### Removing the side cover

Unscrew the screws and lift off the cover.

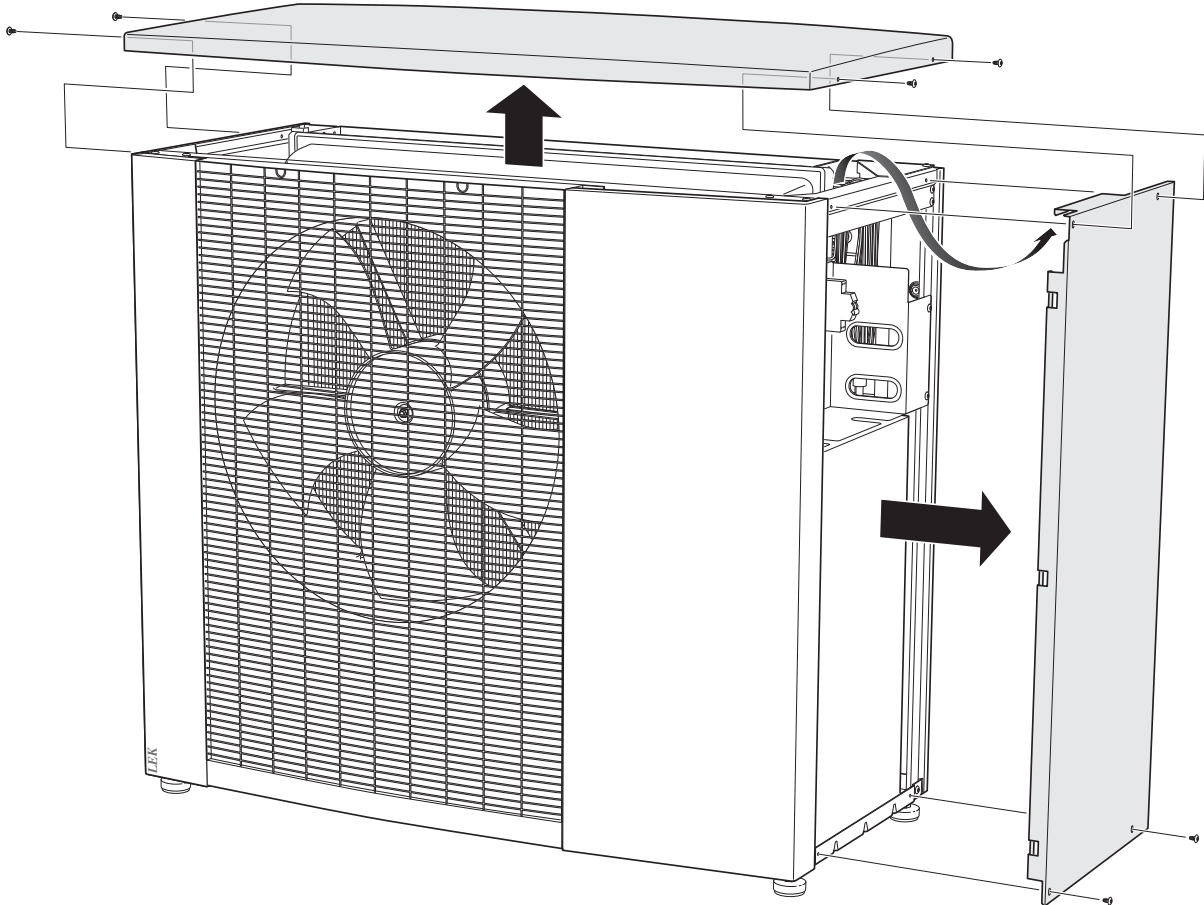

## Configuration using dip switch

The communication address for JÄSPI Inverter Nordic to the indoor module / control module is selected on the base board (AA2). DIP switch S1 is used for configuration of address and functions. For cascade operation with Jäspi MCU 40 for example, addressing is required. JÄSPI Inverter Nordic has the address **1** as standard. In a cascade connection all JÄSPI Inverter Nordic must have a unique address. The address is coded in binary.



### NOTE

Only change the DIP switches position when the product is not powered.

DIP S1 position (1 / 2 / 3)	Slave	Address (com)	Default setting
off / off / off	Slave 1	01	OFF
on / off / off	Slave 2	02	OFF
off / on / off	Slave 3	03	OFF
on / on / off	Slave 4	04	OFF
off / off / on	Slave 5	05	OFF
on / off / on	Slave 6	06	OFF
off / on / on	Slave 7	07	OFF
on / on / on	Slave 8	08	OFF

DIP S1 position	Setting	Function	Default setting
4	ON	Permits cooling	OFF

DIP S2 position	Setting	Default setting
1	OFF	OFF
2	OFF	OFF
3	OFF	OFF
4	OFF	OFF

Switch S3 is the reset button that restarts control.



### Caution

DIP S1 position 4 must be changed to ON in order to run cooling



## Connections



### NOTE

To prevent interference, unshielded communication and/or sensor cables to external connections must not be laid closer than 20 cm from high voltage cables.

### Power connection

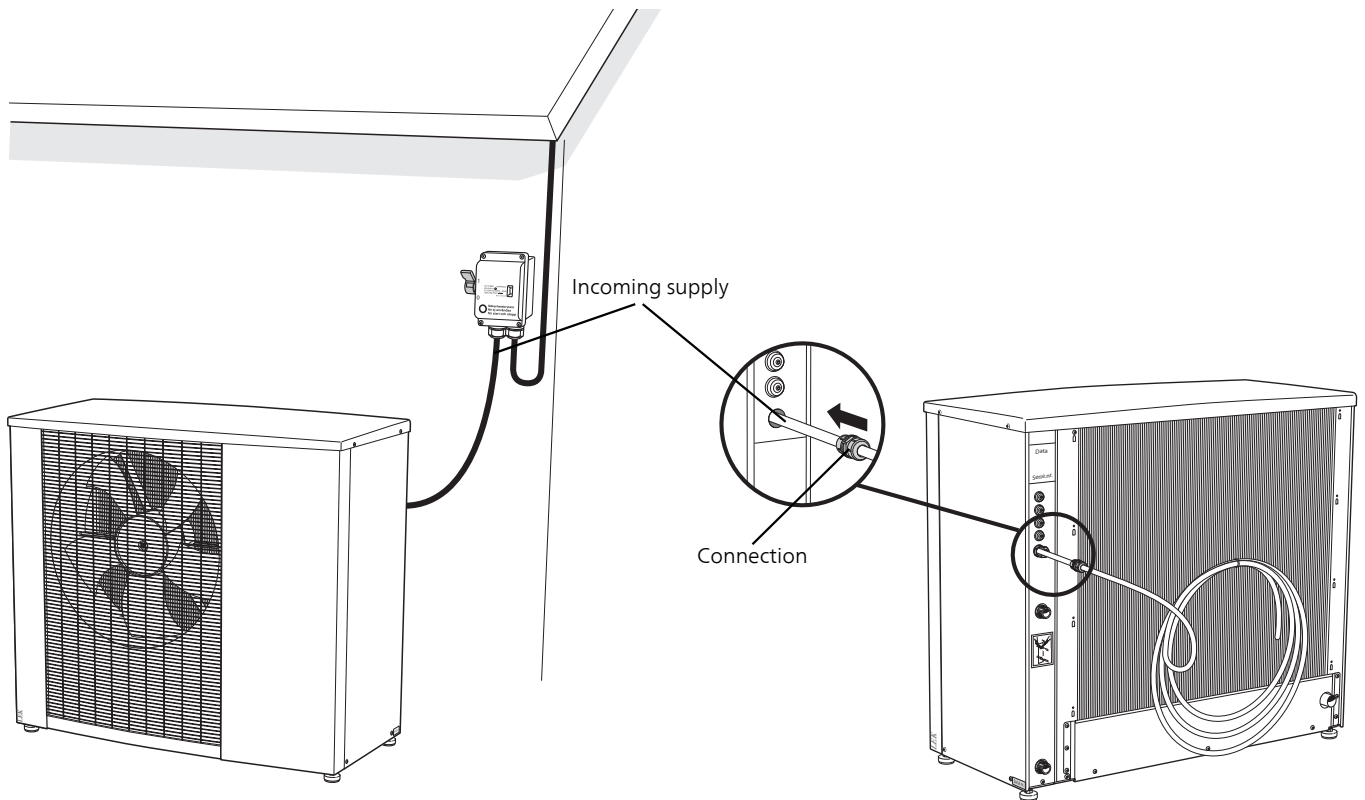

Incoming supply cable is enclosed and factory connected to terminal block X1. Outside the heat pump there is approx. 1.8 m of cable available.

At installation, install the screwed connection on the rear of the heat pump. The part of the screwed joint that tensions the cable must be tightened to a tightening torque above 3.5Nm.

## Connecting external control voltage



### NOTE

Mark up any junction boxes with warnings for external voltage.

When connecting external control voltage, remove the bridges from terminal block X5 (see image).

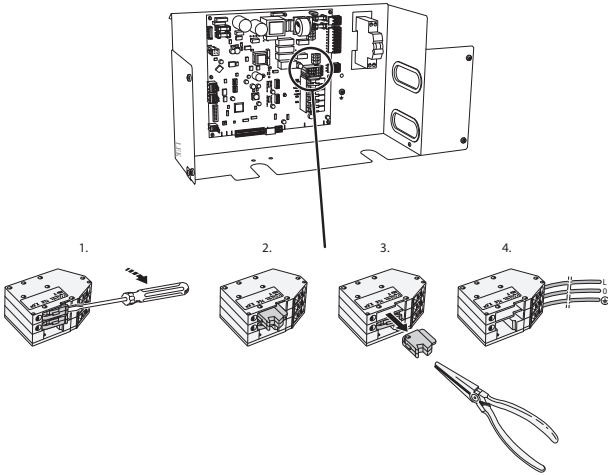

Connect external control voltage (230V~ 50Hz) to terminal block X5:L, X5:N and X5:PE (as illustrated).

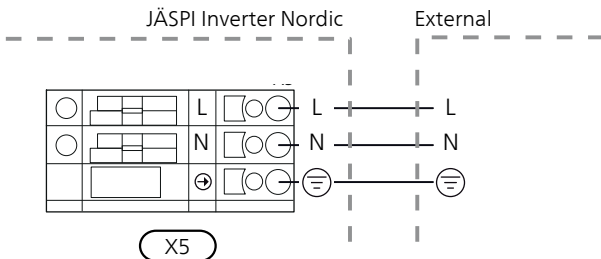

If external control voltage is used during tariff control, connect a closing contact to terminal X21:1 and X21:2 (compressor blocking) to prevent an alarm.

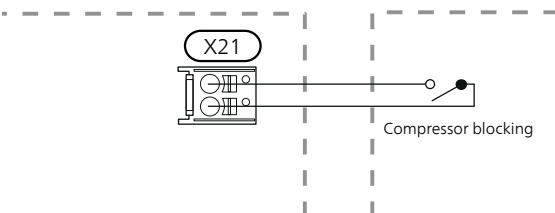

## External heating cable in condensation water pipe (KVR 10)

JÄSPI Inverter Nordic is equipped with a plinth for external heating cable (EB14, not enclosed). The connection is fused with 250 mA (F3) at the factory. If another heating cable is to be used the fuse must be replaced with a suitable one.

Length (m)	Total output (W)	Fuse (F3)	Part No.
1	15	T100mA/250V	718085
3	45	T250mA/250V	518900*
6	90	T500mA/250V	718086

\* Fitted at the factory.

Replace the MCB (FC1) for automatic protection (FB1) when installing KVR 10 if there is no external automatic protection for the installation. Automatic protection (FB1) is available as enclosed component for KVR 10.

Connect external heating cable (EB14) to terminal block X9:L and X9:N. If there is a ground cable connect it to X9:PE. See following image and read further in the installer manual for KVR 10.

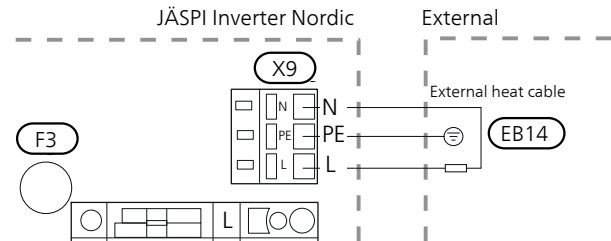

### NOTE

The pipe must be able to withstand the heat from the heating cable.

To ensure this function the accessory KVR 10 should be used.

### Cable routing

The following image shows recommended cable routing from the distribution box to the condensation water trough on the inside of JÄSPI Inverter Nordic. Transition between the electrical cable and the heating cable must occur after the lead-in to the condensation water trough. The distance between the distribution box and the lead-in to the condensation water trough is approx. 1,600 mm.

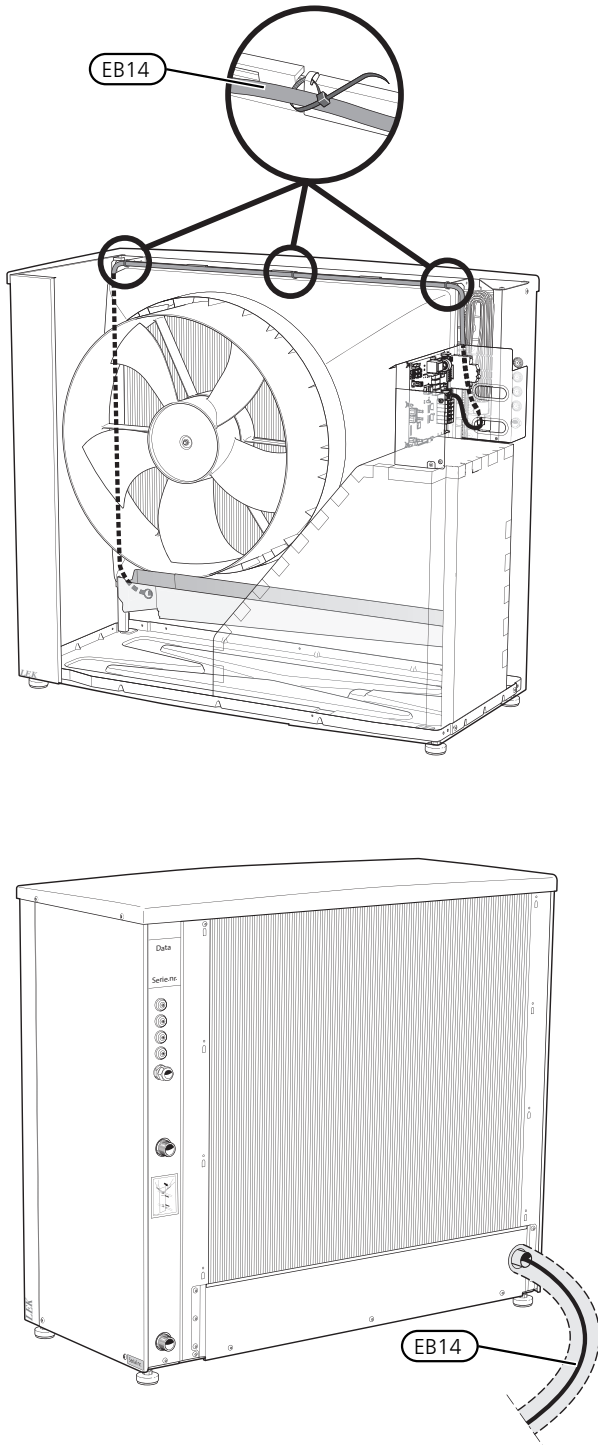

## Optional connections

### Communication

JÄSPI Inverter Nordic communicates with Kaukora indoor modules/control modules by connecting a three core, screened cable (max area 0.75 mm<sup>2</sup>) to terminal block X22:1–4, as shown in the following image. For cascade connection, join terminal block X23 with X22 to the next heat pump.

### Software version

In order for JÄSPI Inverter Nordic to be able to communicate with indoor module / control module the software version must be according to the table.

Indoor module / Control module	Software version
Jäspi Tehowatti AIR	v7865
Jäspi MCU 40	v7839R2

### Disconnect the connections in JÄSPI Inverter Nordic

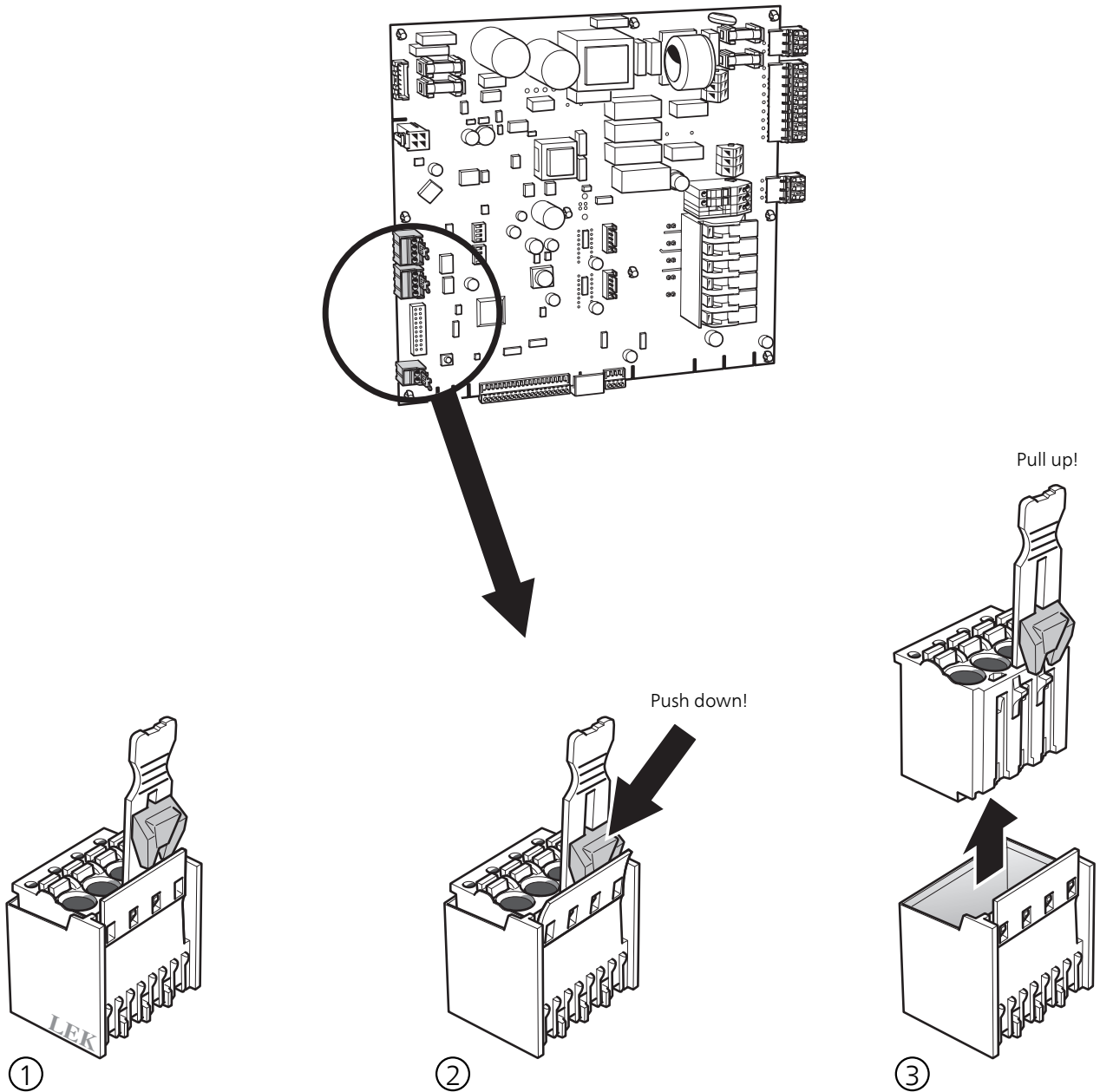

## Jäspi Tehowatti AIR

Indoor module

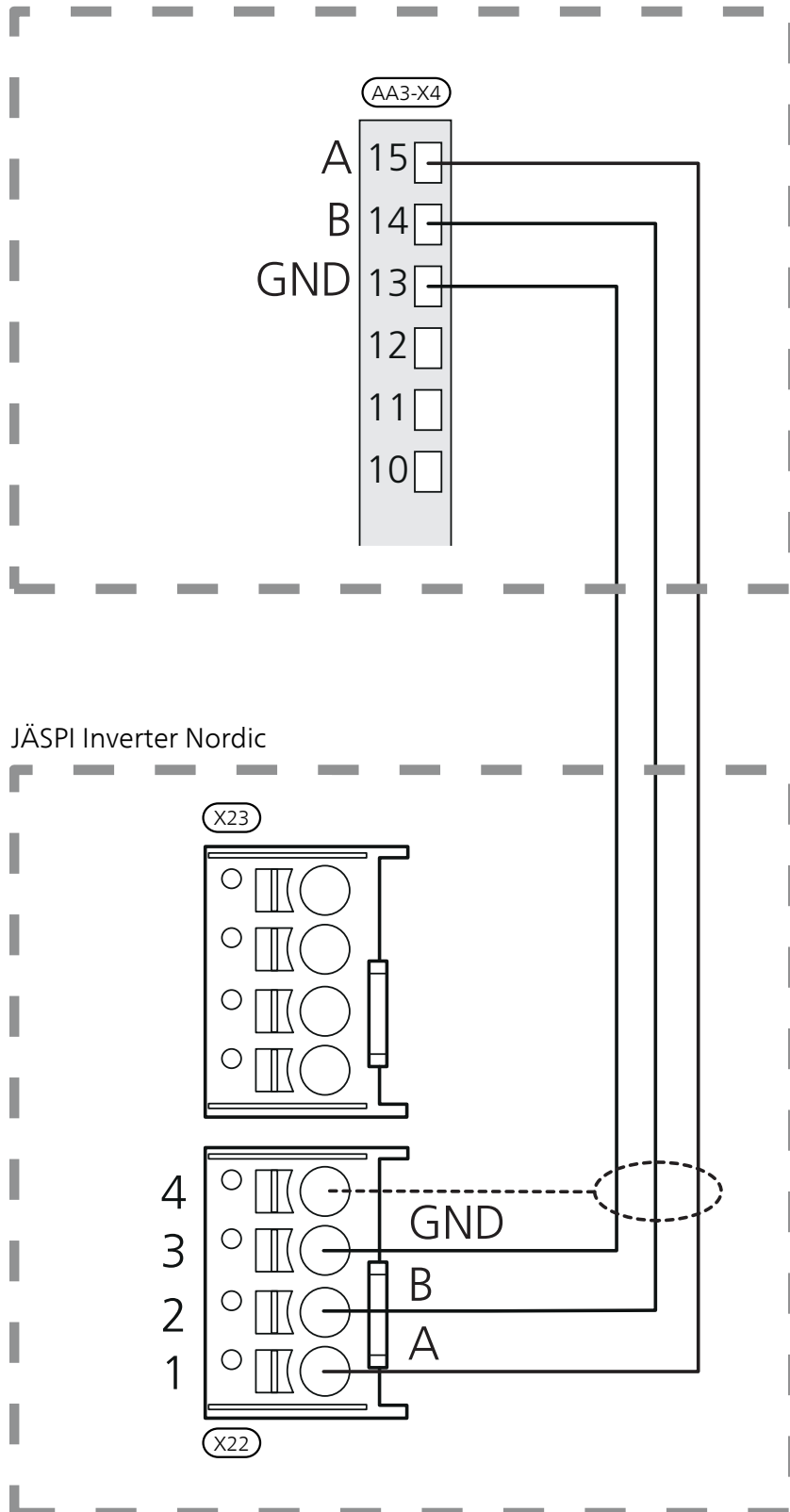

### Jäspi MCU 40

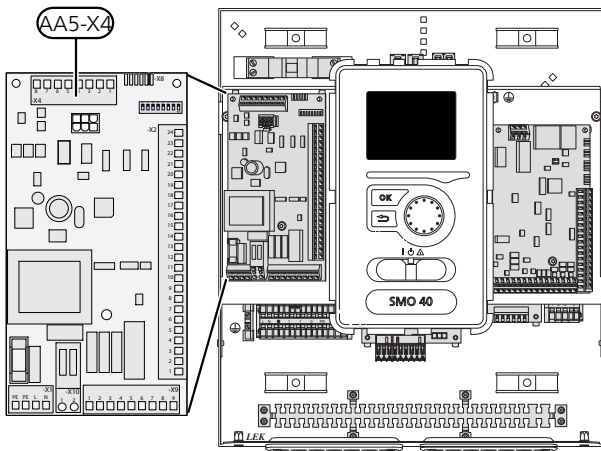

### JÄSPI Inverter Nordic

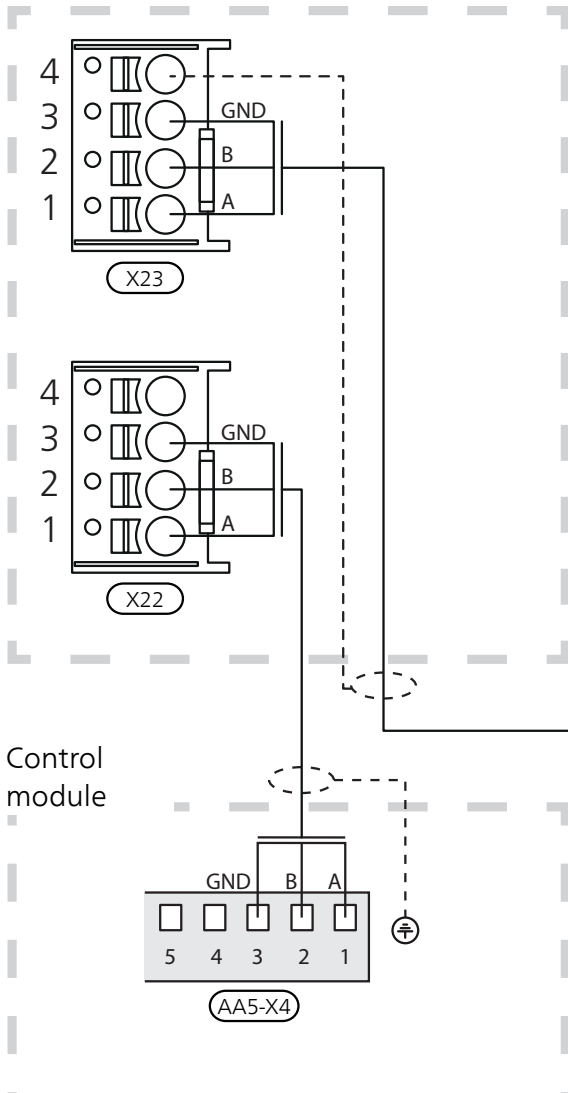

### JÄSPI Inverter Nordic

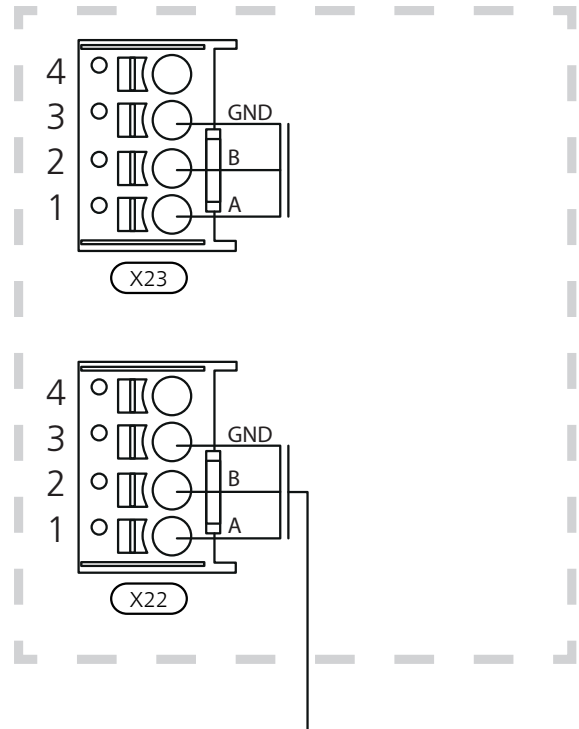

For connection of indoor module/control module, see relevant manual on [www.kaukora.fi](http://www.kaukora.fi).

## Connecting accessories

Instructions for connecting accessories are in the installation instructions provided for the respective accessory. See page 42 for the list of the accessories that can be used with JÄSPI Inverter Nordic.

# 6 Commissioning and adjusting

## Preparations

- Check that the pipe system is prepared.
- Check the pipe system for leaks.
- Check that the electrical installation is prepared.
- Check that the electrical supply is connected so that the compressor heater (EB10) can start warming up the compressor, if necessary.
- The compressor heater (EB10) must have been active for at least 3 hours before compressor operation can be initiated. This is done by connecting control voltage. JÄSPI Inverter Nordic permits compressor start after the compressor has been warmed up. This can take up to 3 hours.

## Filling and venting the heating medium system

1. Fill the heating medium system to the necessary pressure.
2. Vent the system using the venting nipple on the flex hose (enclosed) and possibly the circulation pump.

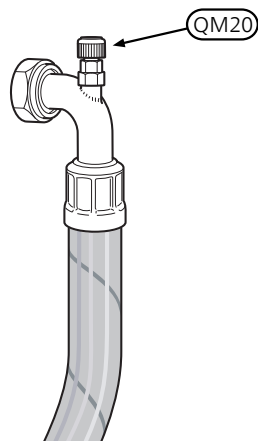

## Start-up and inspection

1. Communication cable, terminal block (X22:1-4) must be connected.
2. If cooling operation with JÄSPI Inverter Nordic is wanted, DIP switch S1 position 4 must be changed according to the description below on page 24.
3. Turn the isolator switch on.
4. Ensure that the JÄSPI Inverter Nordic is connected to the power source.
5. Check that fuse (FC1) is on.
6. Reinstall the removed panels and cover.
7. After the power to JÄSPI Inverter Nordic has been switched on and there is a compressor demand from the indoor module/control module, the compressor starts once it has warmed up, after max 180 minutes. The length of this time delay depends on whether the compressor has been warmed up previously. See chapter Preparations on page 32.
8. Adjust the charge flow according to size. Also see section "Adjustment, charge flow" on page 33.
9. Adjust menu settings via the indoor module/control module as necessary.
10. Fill in the commissioning report in the user manual.
11. Remove the protective film from the cover on JÄSPI Inverter Nordic.



### NOTE

The external control must be taken into consideration when connecting.

## Readjusting, heating medium side

Air is initially released from the hot water and venting may be necessary. If bubbling sounds can be heard from the heat pump, the circulation pump and radiators the entire system will require further venting. When the system is stable (correct pressure and all air eliminated) the automatic heating control system can be set as required.



## Adjustment, charge flow

For correct function of the heat pump over the entire year, the charge flow must be correctly adjusted.

If an Kaukora indoor module Jäspi Tehowatti AIR or accessory controlled charge pump is used for the control module Jäspi MCU 40, the control tries to maintain an optimal flow across the heat pump.

Adjustment may be required, especially for charging a separate water heater. It is therefore recommended to have the option of adjusting the flow across the water heater using a trim valve.

1. Recommendation if there is insufficient hot water and information message "high condenser out" during hot water charging: increase the flow
2. Recommendation if there is insufficient hot water and information message "high condenser in" during hot water charging: reduce the flow

# 7 Control - Introduction

## General

JÄSPI Inverter Nordic is equipped with an internal electronic controller that handles all functions necessary for operation of the heat pump, e. g. defrosting, stop at max/min temperature, connection of the compressor heater, and protective functions during operation.

Temperatures, number of starts and run time, are read off in the indoor module/control module.

The integrated control shows information via status-LEDs and can be used during servicing.

Under normal operating conditions the home owner does not need to have access to the controller.

JÄSPI Inverter Nordic communicates with the Kaukora indoor module/control module, which means that all settings and measurement values from JÄSPI Inverter Nordic are adjusted and read off on the indoor module/control module.

## LED status

The base board (AA2) has six status LEDs for easy control and fault tracing.

LED	State	Explanation
PWR (green)	Not lit	Control board without power
	Continuous light	Control board power on
CPU (green)	Not lit	CPU without power
	Flashes	CPU running
	Continuous light	CPU running incorrectly
EXT COMM (green)	Not lit	No communication with indoor module/control module
	Flashes	Communication with indoor module/control module
INT COMM (green)	Not lit	No communication with inverter
	Flashes	Communication with inverter
DEFROST (green)	Not lit	No defrosting or protection active
	Flashes	Some protection is active
	Continuous light	Defrosting in progress
ERROR (red)	Not lit	No errors
	Flashes	Infoalarm (temporary), active
	Continuous light	Continuous alarm, active
K1, K2, K3, K4, K5	Not lit	Relay in de-energised position
	Continuous light	Relay engaged

LED	State	Explanation
N-RELAY		No function
COMPR. ON		No function

## Master control

To control JÄSPI Inverter Nordic, a Kaukora indoor module/control module is required, which calls upon JÄSPI Inverter Nordic according to demand. All settings for JÄSPI Inverter Nordic are made via the indoor module/control module. It also shows the status and sensor values from JÄSPI Inverter Nordic.

Description	Value	Parameter space	Unit
Cut-out value activation passive defrosting	4	4 – 14	°C
Start temperature BT16 to calculate index	-3	-5 – 5	°C
Permit fan de-icing	No	Yes / No	(1 / 0)
Permit silent mode	No	Yes / No	(1 / 0)
Permit defrost more often	No	Yes / No	(1 / 0)

## Control conditions

### Control conditions defrosting

- If the temperature on the evaporation sensor (BT16) is below the start temperature for the defrosting function, JÄSPI Inverter Nordic counts the time to "active defrosting" each minute that the compressor is running, to create a defrosting requirement.
- Time until "active defrosting" is shown in minutes on the indoor module / control module. Defrosting starts when this value is 0 minutes.
- "Passive defrosting" is started, if the compressor requirement has been fulfilled, at the same time as there is a defrosting requirement and the outdoor temperature (BT28) is greater than 4 °C.
- Defrosting occurs actively (with compressor on and fan off) or passively (with compressor off and fan on).
- If the evaporator is too cold, a "safety defrost" starts. This defrosting can be started earlier than the normal defrosting. If there are ten safety defrostings in a row the evaporator (EP1) on JÄSPI Inverter Nordic must be checked, which is indicated by alarm 341.
- If "de-icing fan" is activated in menu 5.11.1.1, "de-icing fan" starts at the next "active defrosting". "De-icing fan" removes the build-up of ice on the fan blades and the front fan grille.

#### Active defrosting:

1. The four way valve shifts to defrosting.
2. The fan stops and the compressor continues to run.
3. When defrosting is complete, the four-way valve switches back to heating operation. The compressor speed is locked for a short period.
4. The ambient temperature is locked and the high return temperature alarm is blocked for two minutes after defrosting.

#### Passive defrosting:

1. If any compressor requirement is available, passive defrosting can start.
2. The four way valve does not shift.
3. Fan runs at high speed.
4. If there is a compressor demand, passive defrosting stops and the compressor starts.
5. When passive defrosting is complete, the fan stops.
6. The ambient temperature is locked and the high return temperature alarm is blocked for two minutes after defrosting.

#### ***There are several possible reasons for an active defrosting to end:***

1. If the temperature of the evaporator sensor has reached its stop value (normal stop).
2. When defrosting has gone on for longer than 15 minutes. This may be due to too little energy in the heat source, too strong a wind effect on the evaporator and/or that the sensor on the evaporator is not correct and therefore displays too low a temperature (at cold outdoor air).

3. When the temperature on the return line sensor, BT3, falls below 10 °C.
4. If the temperature of the evaporator (BP8) falls below its lowest permitted value. After ten unsuccessful defrostings, JÄSPI Inverter Nordic must be checked. This is indicated as an alarm 228.

## Control - Heat pump EB101

### Heat pump menu 5.11.1.1

These settings are made on the display on the indoor module/control module.

#### **Silent mode permitted**

Set whether silent mode is to be activated for the heat pump here. Note that it is possible to schedule when silent mode is to be active.

#### **Detect compressor phase**

This shows on which the phase the heat pump has detected whether you have JÄSPI Inverter Nordic 230V~50Hz. Phase detection normally occurs automatically in connection with start-up of the indoor module/control module. This setting can be changed manually.

#### **Current limit**

Set whether the current limiting function is to be activated for the heat pump here. During active function you can limit the value of the maximum current.

Setting range: 6 – 32 A

Factory setting: 32 A

#### **blockFreq 1**

Select a frequency range within which the heat pump may work here. This function can only be used if certain compressor speeds cause noise disturbance in the house.

#### **blockFreq 2**

Select a frequency range within which the heat pump may work here.

### **Defrosting**

Here you can change the settings that affect the defrost function.

#### **Start temperature for defrost function**

Here you can set at which temperature (BT16) the defrost function is to start. The value must only be changed in consultation with your installer.

Setting range: -5 – 5 °C

Factory setting: -3 °C

#### **Cut-out value activation passive defrosting**

Here you can set at which temperature (BT28) passive defrosting is to be activated. During passive defrosting, the ice is melted by the energy from the ambient air. The fan is active during passive defrosting. The value must only be changed in consultation with your installer.

Setting range: 2 – 10 °C

Factory setting: 4 °C

#### **Permit defrost more often**

Here you activate whether defrosting is to occur more frequently than normal. The selection can be made again if the heat pump receives an alarm due to build-up of ice during operation caused by snow, for example.

#### **Permit fan de-icing**

Set whether the "de-icing fan" must be deactivated during the next "active defrosting" here. This can be activated if ice / snow sticks to the fan, grille or fan cone, which is noticed because of abnormal fan noise from JÄSPI Inverter Nordic.

"De-icing fan" means that the fan, grille or fan cone is heated using hot air from the exchanger (EP1). Therefore the function should not be used in windy weather.

#### **Start manual defrosting**

Here you can manually start an "active defrosting", in the event that the function must be tested for servicing or if operation is necessary. This can be motivated together with "de-icing fan".

# 8 Disturbances in comfort

## Troubleshooting



### NOTE

Work behind covers secured by screws may only be carried out by, or under the supervision of, a qualified installation engineer.



### NOTE

As JÄSPI Inverter Nordic can be connected to a large number of external units, these should also be checked.



### NOTE

In the event of action to rectify malfunctions that require work within screwed hatches the incoming electricity must be isolated at the safety switch.



### NOTE

The alarm is acknowledged on the indoor module/control module (JÄSPI Tehowatti Air / JÄSPI MCU40) or by the voltage to the heat pump being interrupted and then restarted.

The following tips can be used to rectify comfort disruption:

### Basic actions

Start by checking the following possible fault sources:

- That the heat pump is running or that the supply cable to JÄSPI Inverter Nordic is connected.
- Group and main fuses of the accommodation.
- The property's earth circuit breaker.
- The heat pump's miniature circuit breaker (FC1).
- Heat pump's earth-fault breaker.
- JÄSPI Inverter Nordic automatic protection (FB1). (Only if KVR 10 is installed.)

### Low hot water temperature or a lack of hot water

This part of the fault-tracing chapter only applies if the heat pump is docked to the hot water heater.

- Large hot water consumption.
  - Wait until the hot water has heated up.
- Incorrect settings indoor module or control module.
  - See the manual for the indoor module or control module.
- Clogged particle filter.
  - Check whether alarm "high condenser out" (162) is an info message. Check and clean the particle filter.

### Low room temperature

- Closed thermostats in several rooms.
  - Set the thermostats to max in as many rooms as possible.
- External switch for changing the room heating activated.
  - Check any external switches.
- Incorrect settings in indoor module or control module.
  - See the manual for the indoor module / control module (JÄSPI Tehowatti Air / JÄSPI MCU40).
- Incorrect flow across the heat pump.
  - Check whether alarm "high condenser in" (163) or "high condenser out" (162) are info messages. Follow the instructions for adjusting charge flow.

### High room temperature

- External switch for changing the room heating activated.
  - Check any external switches.
- Incorrect settings in indoor module or control module.
  - See the manual for the indoor module or control module.

### JÄSPI Inverter Nordic not in operation

JÄSPI Inverter Nordic communicates all alarms to the indoor module/control module (JÄSPI Tehowatti Air / JÄSPI MCU40).

- Ensure that the JÄSPI Inverter Nordic is connected to the power source and that compressor operation is required.
- Check the indoor module/control module (JÄSPI Tehowatti Air / JÄSPI MCU40). See section "Disturbances in comfort" in the Installer Manual for the indoor module/control module (JÄSPI Tehowatti Air / JÄSPI MCU40).

### JÄSPI Inverter Nordic does not communicate

- Check that the addressing of JÄSPI Inverter Nordic is correct.
- Check that the communication cable has been connected.

### Ice build-up in the fan, grille and/or fan cone

- De-icing fan is not activated.
  - Activate "de-icing fan" (menu 5.11.1.1).

### Large amount of water below JÄSPI Inverter Nordic

Check water drainage capacity of KVR 10.

## Sensor placement

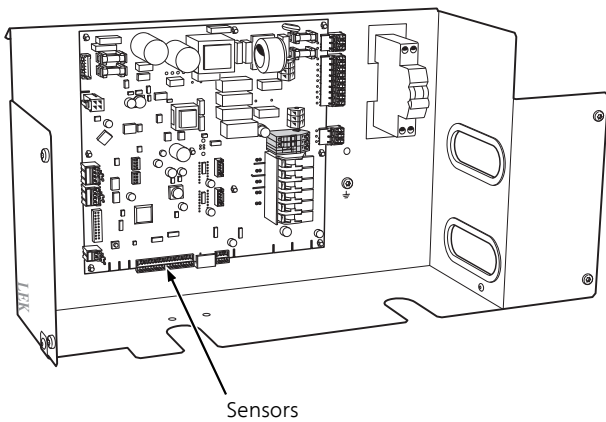

- BP8 Low pressure transmitter
- BP9 High pressure sensor
- BP11 Pressure sensor, injection
- BT3 Temperature sensor, return
- BT12 Temperature sensor, condenser supply line
- BT14 Temperature sensor, hot gas
- BT15 Temperature sensor, fluid pipe
- BT16 Temperature sensor, evaporator
- BT17 Temperature sensor, suction gas
- BT28 Temperature sensor, ambient
- BT81 Temperature sensor, injection, EVI compressor
- BT84 Temperature sensor, suction gas, evaporator

### Data for temperature sensor return line (BT3), condenser supply (BT12), fluid pipe (BT15) and injection (BT81)

Temperature (°C)	Resistance (kOhm)	Voltage (VDC)
-40	351.0	3.256
-35	251.6	3.240
-30	182.5	3.218
-25	133.8	3.189
-20	99.22	3.150
-15	74.32	3.105
-10	56.20	3.047
-5	42.89	2.976
0	33.02	2.889
5	25.61	2.789
10	20.02	2.673
15	15.77	2.541
20	12.51	2.399
25	10.00	2.245
30	8.045	2.083
35	6.514	1.916
40	5.306	1.752
45	4.348	1.587
50	3.583	1.426
55	2.968	1.278
60	2.467	1.136
65	2.068	1.007
70	1.739	0.891
75	1.469	0.785
80	1.246	0.691
85	1.061	0.607
90	0.908	0.533
95	0.779	0.469
100	0.672	0.414

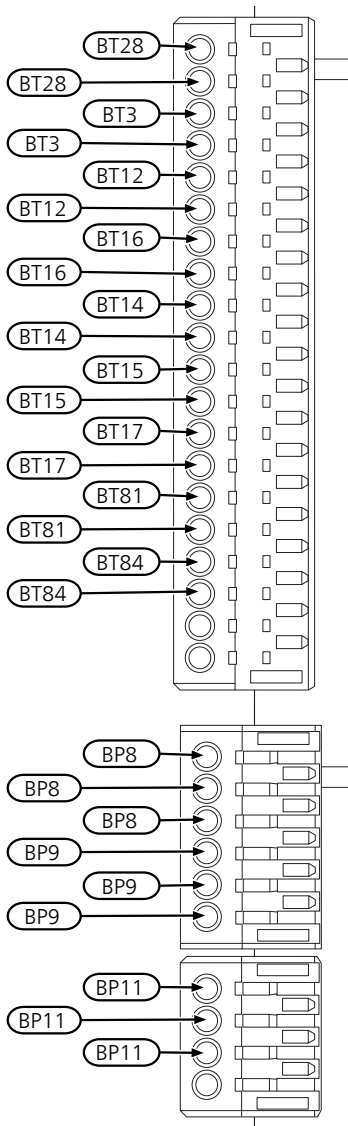

**Data for hot gas sensor (BT14)**

Temperature (°C)	Resistance (kOhm)	Voltage (V)
40	118.7	4.81
45	96.13	4.77
50	78.30	4.72
55	64.11	4.66
60	52.76	4.59
65	43.64	4.51
70	36.26	4.43
75	30.27	4.33
80	25.38	4.22
85	21.37	4.10
90	18.07	3.97
95	15.33	3.83
100	13.06	3.68
105	11.17	3.52
110	9.59	3.36
115	8.26	3.19
120	7.13	3.01
125	6.18	2.84
130	5.37	2.67
135	4.69	2.50
140	4.10	2.33

**Data for evaporator sensor (BT16), ambient sensor (BT28), suction gas sensor (BT17) and suction gas, evaporator (BT84)**

Temperature (°C)	Resistance (kOhm)	Voltage (VDC)
-50	77.58	4.71
-45	57.69	4.62
-40	43.34	4.51
-35	32.87	4.37
-30	25.17	4.21
-25	19.43	4.03
-20	15.13	3.82
-15	11.88	3.58
-10	9.392	3.33
-5	7.481	3.07
0	6.000	2.80
5	4.844	2.54
10	3.935	2.28
15	3.217	2.03
20	2.644	1.80
25	2.186	1.59
30	1.817	1.39
35	1.518	1.22
40	1.274	1.07
45	1.075	0.93
50	0.911	0.81
55	0.775	0.71
60	0.662	0.62
65	0.568	0.54
70	0.490	0.47
75	0.4233	0.41
80	0.367	0.36
85	0.320	0.32
90	0.280	0.28
95	0.245	0.25
100	0.216	0.22

## 9 Alarm list

Alarm	(Alarm)	Alarm text on the display	Description existing alarm	May be due to
156	80	Low lp cooling	5 repeated low low-pressure sensor alarm within 4 hours.	Poor flow.
224	182	Fan alarm from heat pump	5 unsuccessful start attempt.	Fan blocked or not connected.
225	8	Exchange. Sensors flow/return	Return is hotter than flow.	Connection, supply line return line switched around,
227	34 36 38 40 42 44 46 48 50 52 54 56	Sensor fault from heat pump	Sensor fault BT3. Sensor fault BT12. Sensor fault BT14. Sensor fault BT15. Sensor fault BT16. Sensor fault BT17. Sensor fault BT28. Sensor fault BT81. Sensor fault BP8. Sensor fault BP9. Sensor fault BP11. Sensor fault BT84.	Open-circuit or short-circuit on sensor input.
228	2	Unsuccessful defrosting	Defrosting could not be completed 10 times in a row.	System temperature and/or flow too low.
229	4	Short run times for compressor	Operation is stopped from the indoor section after less than 5 minutes.	Poor flow, poor heat transfer.
230	78	Hot gas alarm	3 repeated low hot gas sensor alarm within 4 hours.	Refrigerant leakage.
232	76	Low evaporation temp	5 repeated low evaporation sensor alarm within 4 hours.	Refrigerant leakage, blocked expansion valve.
264	204	Communication fault with Inverter.	5 communication fault with inverter.	Inverter unpowered or broken.
341	6	Recurring safety defrosting	10 repeated defrostings according to the protection conditions.	Poor airflow, because of leaves, dirt, snow or ice.
344	72	Recurring low pressure	5 repeated low pressure alarm within 4 hours.	Refrigerant leakage, blocked expansion valve.
346	74	Recurring high pressure	5 repeated high pressure alarm within 4 hours.	Stop the heating medium flow, poor system pressure, blocked expansion valve.
400	207 209 211 213	Unspecified faults	Initiation fault inverter. Inverter not compatible. Configuration file missing. Charge error configuration.	Incorrect inverter size.
421	104	Inverter alarm type II	3 repeated communication errors within 2 hours.	Communication with AA2-X20 interrupted.
425	108	Deployed pressure switch	2 repeated LP/HP pressure switch alarms within 2.5 hours.	Poor heating medium flow, refrigerant leakage.
431	114	Inverter alarm type I	Phase voltage to inverter too high, 3 times within 2 hours or persistent for 1 hour.	High voltage in to JÄSPI Inverter Nordic.



Alarm	(Alarm)	Alarm text on the display	Description existing alarm	May be due to
433	116	Inverter alarm type I	Phase voltage to inverter too low, below 180V, 3 times within 2 hours or persistent for 1 hour.	Low voltage or dropped phase to JÄSPI Inverter Nordic.
435	118	Inverter alarm type I	A compressor phase is missing, 3 times within 2 hours or persistent for 1 hour.	At least one compressor phase is missing.
441	124	Inverter alarm type II	Phase voltage to inverter too high, 3 times within 2 hours.	Too high current to inverter.
445	128	Inverter alarm type II	Temporary fault in inverter, 3 times within 2 hours.	Interruption in voltage supply to the inverter
467	140	Inverter error	Too low incoming voltage to JÄSPI Inverter Nordic.	Incoming voltage too low (1 phase).

# 10 Accessories

## Condensation water pipe

Condensation water pipe, different lengths.

### ***KVR 10-10***

1 metres

Part no. 067 549

### ***KVR 10-30***

3 metres

Part no. 067 550

### ***KVR 10-60***

6 metres

Part no. 067 551

## Control module

### ***JÄSPI MCU40***

Control module

LVI Code 526 01 53

## Indoor module

### ***JÄSPI Tehowatti Air***

**Stainless Steel, 3 x 400 V**

LVI Code 505 85 28

## Water heater/Accumulator tank

### ***JÄSPI Buffer 100***

LVI Code 505 85 28

### ***JÄSPI Buffer 270***

LVI Code 536 01 56

### ***JÄSPI Buffer 200***

LVI Code 536 01 19

### ***JÄSPI Buffer 500***

LVI Code 536 01 57

# 11 Technical data

## Dimensions

### JÄSPI Inverter Nordic-8

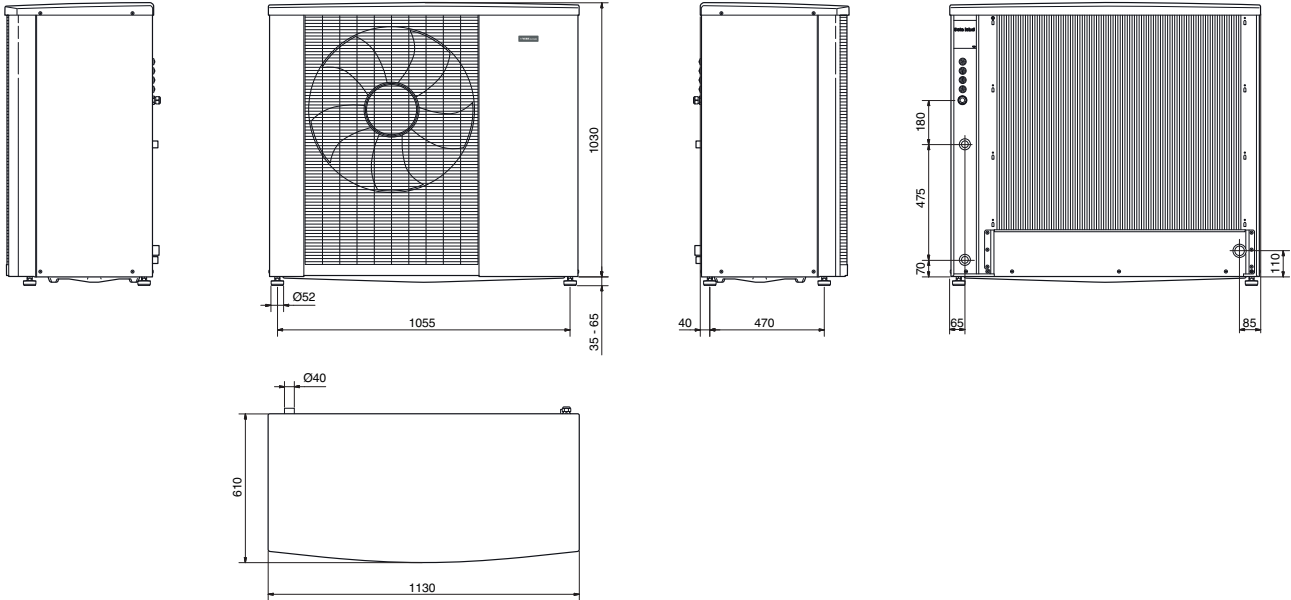

### JÄSPI Inverter Nordic-12, -16, -20

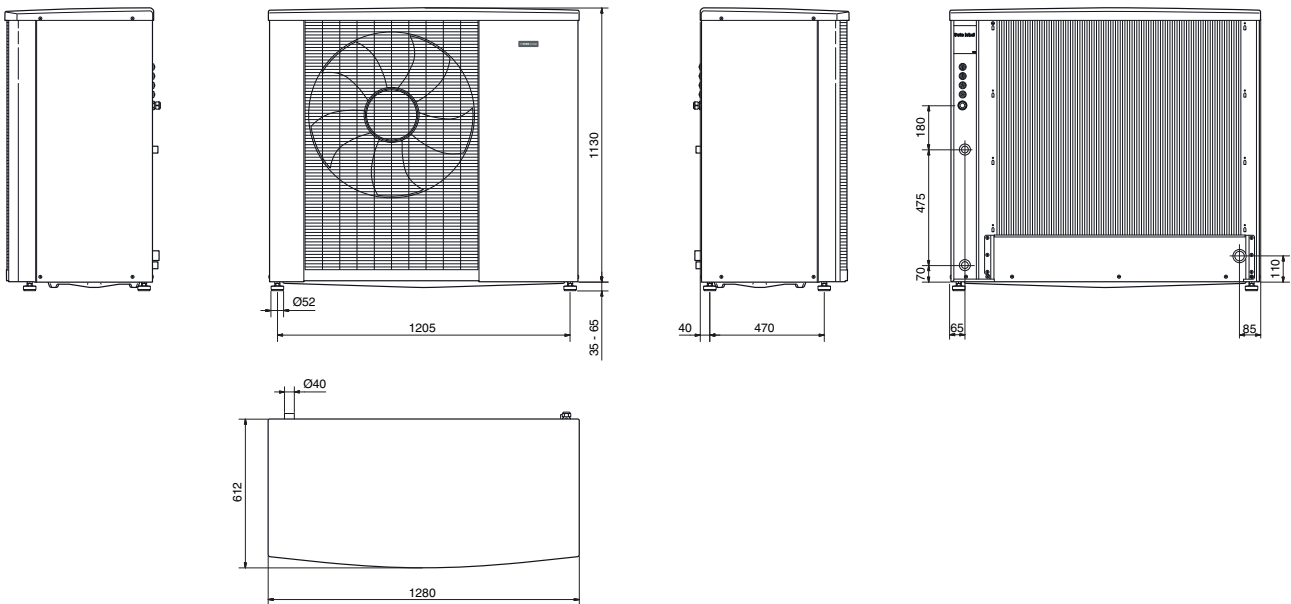

## Sound pressure levels

JÄSPI Inverter Nordic is usually placed next to a house wall, which gives a directed sound distribution that should be considered. Accordingly, you should always

attempt when positioning to choose the side that faces the least sound sensitive neighbouring area.

The sound pressure levels are further affected by walls, bricks, differences in ground level, etc and should therefore only be seen as guide values.

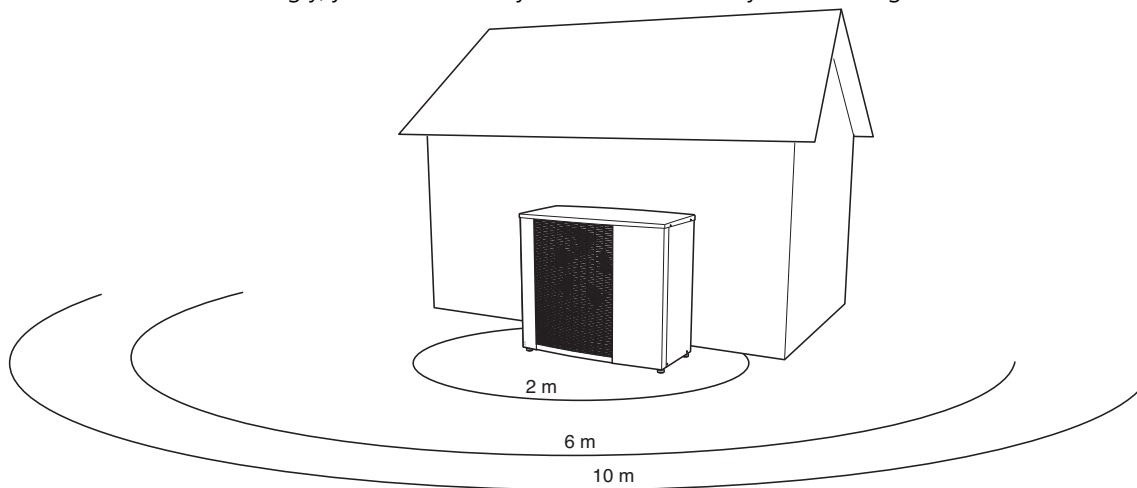

JÄSPI Inverter Nordic		8	12	16	20
Sound power level ( $L_{WA}$ ), according to EN12102 at 7 / 45 (nominal)	$L_W(A)$	53	53	53	53
Sound pressure level ( $L_{pA}$ ) at 2 m*	dB(A)	39	39	39	39
Sound pressure level ( $L_{pA}$ ) at 6 m*	dB(A)	29.5	29.5	29.5	29.5
Sound pressure level ( $L_{pA}$ ) at 10 m*	dB(A)	25	25	25	25

\*Free space.

## Technical specifications

JÄSPI Inverter Nordic – 1x230V		8
<b>Heating</b>		
<b>Output data according to EN 14511, partial load<sup>1)</sup></b>		
7/35 Rated output / Supplied power / COP <sub>EN14511</sub>	kW/kW/-	3.57 / 0.78 / 4.57
7/45 Rated output / Supplied power / COP <sub>EN14511</sub>	kW/kW/-	3.66 / 0.98 / 3.74
2/35 Rated output / Supplied power / COP <sub>EN14511</sub>	kW/kW/-	4.03 / 0.91 / 4.43
2/45 Rated output / Supplied power / COP <sub>EN14511</sub>	kW/kW/-	4.07 / 1.16 / 3.51
<b>Cooling</b>		
	Outd. temp: / Supply temp.	Max
<b>Output data according to EN14511 <math>\Delta T5K</math> Specified/supplied power/EER</b>	35 / 7 °C	3.80 / 1.28 / 2.97
	35 / 18 °C	5.10 / 1.37 / 3.73
<b>Electrical data</b>		
Rated voltage		230V~50Hz
Max operating current, heat pump	A <sub>rms</sub>	14
Max operating current, compressor	A <sub>rms</sub>	13
Max output, fan	W	40
Fuse	A <sub>rms</sub>	16
<b>Refrigerant circuit</b>		
Type of refrigerant		R410A
GWP refrigerant		2,088
Type of compressor		Scroll
Volume	kg	2.4
CO <sub>2</sub> equivalent	t	5.01
Cut-out value pressure switch HP (BP1)	MPa	4.5
Difference pressostat HP	MPa	0.7
Cut-out value pressostat LP	MPa	0.12
Difference pressostat LP	MPa	0.7
<b>Airflow</b>		
Max airflow	m <sup>3</sup> /h	2,400
Min/Max air temp, max	°C	-25 / 43
Defrosting system		reverse cycle
<b>Water flow</b>		
Max system pressure heating medium	MPa	0.45 (4.5 bar)
Min/Max flow	l/s	0.08 / 0.32
Min/Max HM temp continuous operation	°C	26 / 65
Connection heating medium JÄSPI Inverter Nordic		G1 1/4" external thread
Connection heating medium flex pipe		G1 external thread
<b>Dimensions and weight</b>		
Width	mm	1,130
Depth	mm	610
Height with stand	mm	1,070
Weight (excl. packaging)	kg	150

JÄSPI Inverter Nordic – 1x230V	8
<b>Miscellaneous</b>	
Enclosure class	IP24
Colour	grey
Part No.	536 01 79

JÄSPI Inverter Nordic – 3x400V		8	12	16	20	
<b>Heating</b>						
<b>Output data according to EN 14511, partial load<sup>1)</sup></b>						
7/35 Rated output / Supplied power / COP <sub>EN14511</sub>	kW/kW/-	3.57/0.78/4.57	3.54/0.69/5.12	5.17/1.01/5.11	5.17/1.01/5.11	
7/45 Rated output / Supplied power / COP <sub>EN14511</sub>	kW/kW/-	3.66/0.98/3.74	3.64/0.91/4.00	5.49/1.33/4.14	5.49/1.33/4.14	
2/35 Rated output / Supplied power / COP <sub>EN14511</sub>	kW/kW/-	4.03/0.91/4.43	5.21/1.22/4.27	7.80/1.79/4.36	9.95/2.36/4.22	
2/45 Rated output / Supplied power / COP <sub>EN14511</sub>	kW/kW/-	4.07/1.16/3.51	5.27/1.49/3.54	7.97/2.24/3.56	10.41/2.88/3.61	
<b>Cooling</b>						
	Outd. temp: / Supply temp.	Max	Max	Max	Max	
<b>Output data according to EN14511 ΔT5K</b>		35 / 7 °C	3.80/1.28/2.97	4.69/1.70/2.76	7.09/2.72/2.61	8.10/3.50/2.31
Specified/supplied power/EER		35 / 18 °C	5.10/1.37/3.73	5.44/1.73/3.15	8.19/2.83/2.90	9.26/3.64/2.54
<b>Electrical data</b>						
Rated voltage		400V 3N~50Hz				
Max operating current, heat pump	A <sub>rms</sub>	6	7	9.5	11	
Max operating current, compressor	A <sub>rms</sub>	5	6	8.5	10	
Max output, fan	W	40	45	68	80	
Fuse	A <sub>rms</sub>	10	10	10	13	
<b>Refrigerant circuit</b>						
Type of refrigerant		R410A				
GWP refrigerant		2,088				
Type of compressor		Scroll				
Volume	kg	2.4	2.6	3	3	
CO <sub>2</sub> equivalent	t	5.01	5.43	6.26	6.26	
Cut-out value pressure switch HP (BP1)	MPa	4.5				
Difference pressostat HP	MPa	0.7				
Cut-out value pressostat LP	MPa	0.12				
Difference pressostat LP	MPa	0.7				
<b>Airflow</b>						
Max airflow	m <sup>3</sup> /h	2,400	3,400	4,150	4,500	
Min/Max air temp, max	°C	-25 / 43				
Defrosting system		reverse cycle				
<b>Water flow</b>						
Max system pressure heating medium	MPa	0.45 (4.5 bar)				
Min/Max flow	l/s	0.08/0.32	0.11/0.44	0.15/0.60	0.19/0.75	
Min flow defrosting (100 % pump speed)	l/s	0.27	0.35	0.38	0.48	
Min/Max HM temp continuous operation	°C	26 / 65				
Connection heating medium JÄSPI Inverter Nordic		G1 1/4" external thread				
Connection heating medium flex pipe		G1 external thread		G1 1/4" external thread		
<b>Dimensions and weight</b>						
Width	mm	1,130		1,280		
Depth	mm	610		612		
Height with stand	mm	1,070		1,165		
Weight (excl. packaging)	kg	167	177	183		

JÄSPI Inverter Nordic – 3x400V	8	12	16	20
<b>Miscellaneous</b>				
Enclosure class	IP24			
Colour	Grey			
Part No.	5360173	5360174	5360175	5360176

SCOP & Pdesign JÄSPI Inverter Nordic according to EN 14825								
JÄSPI Inverter Nordic	8		12		16		20	
	Pdesign	SCOP	Pdesign	SCOP	Pdesign	SCOP	Pdesign	SCOP
SCOP 35 Average climate (Europe)	5.9	4.80	8	4.83	11	5.05	11	5.05
SCOP 55 Average climate (Europe)	6.3	3.75	8.3	3.78	12.3	3.9	12.3	3.9
SCOP 35 Cold climate	6.8	4.03	9.3	4.05	13	4.25	13	4.25
SCOP 55 Cold climate	7.4	3.33	9.8	3.33	14	3.53	14	3.53
SCOP 35 Warm climate	5.9	5.43	9.2	5.48	13	5.5	13	5.5
SCOP 55 Warm climate	6.3	4.35	9.2	4.48	13	4.5	13	4.5

<sup>1</sup>)Power statements including defrosting according to EN14511 at heating medium supply corresponding to DT=5 K at 7 / 45.

<sup>2</sup>)Nominal flow corresponds to DT=10 K at 7 / 45.



# Working area

## JÄSPI Inverter Nordic-8 working range

Supply temperature (°C)

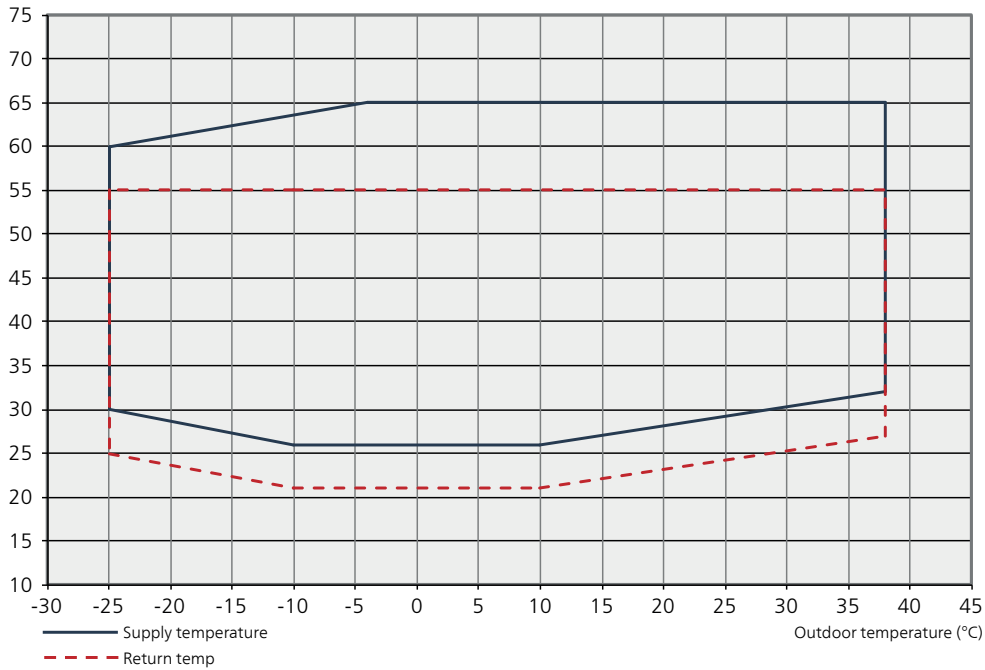

## JÄSPI Inverter Nordic-12 working range

Supply temperature (°C)

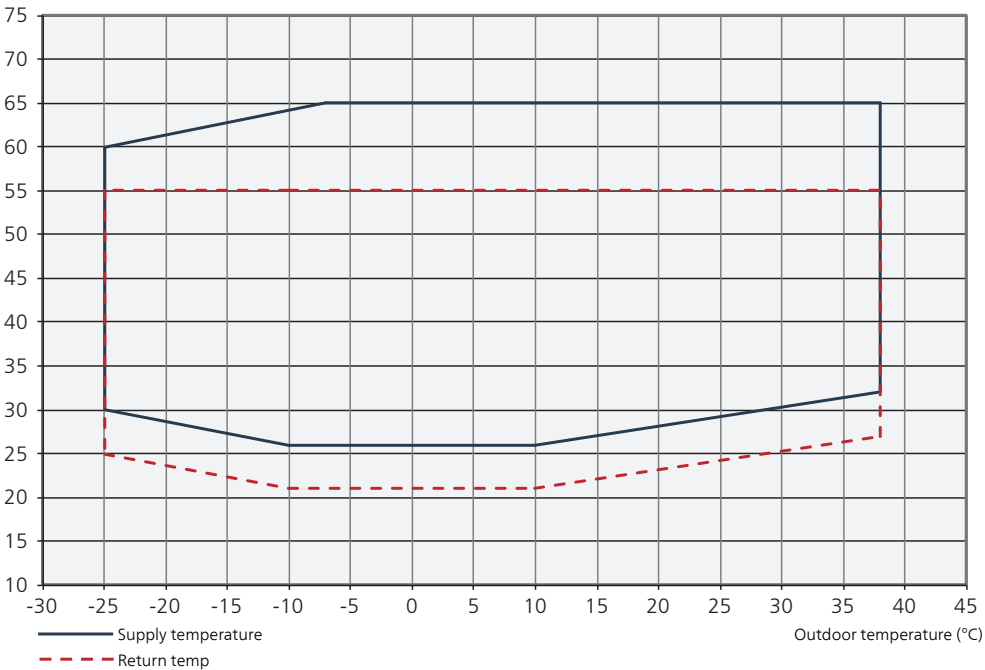

*JÄSPI Inverter Nordic-16 / JÄSPI Inverter Nordic-20 working range*

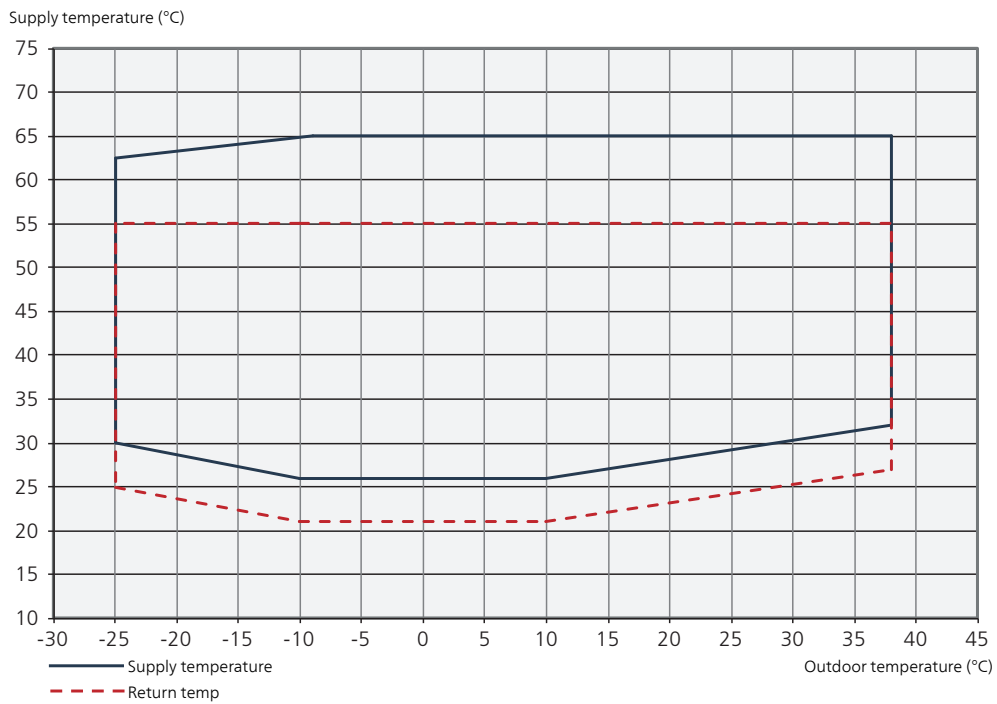

*JÄSPI Inverter Nordic working range cooling*

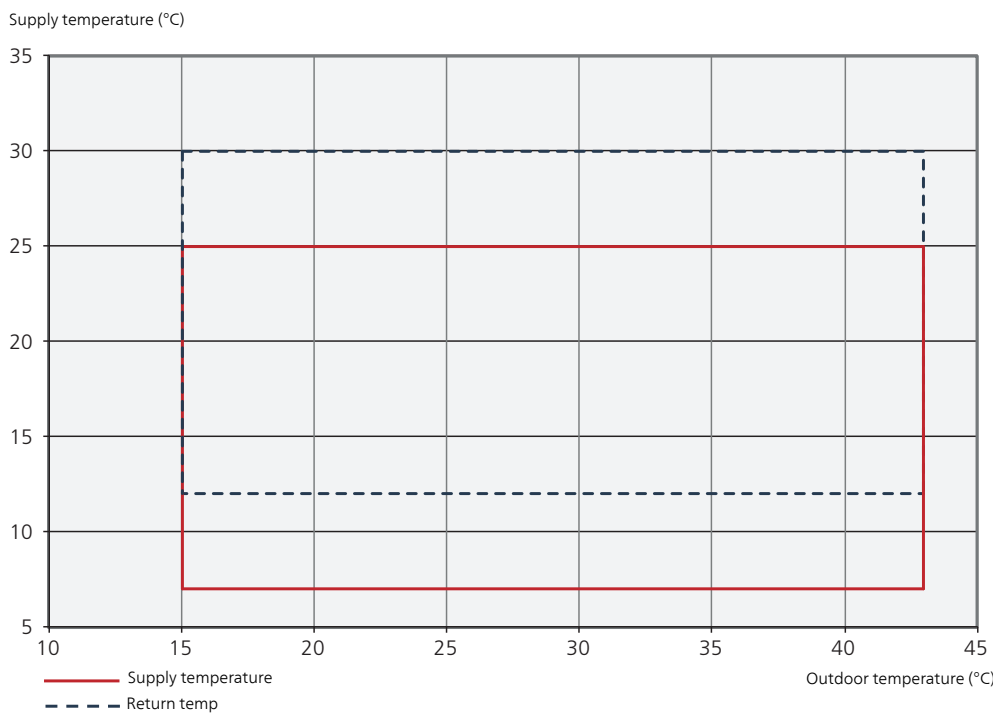

During shorter time it is allowed to have lower working temperatures on the water side, e.g. during start up.

# Heating

## Output and COP at different supply temperatures

Maximum output during continuous operation.

### JÄSPI Inverter Nordic-8

JÄSPI Inverter Nordic-8 max and min heating capacity

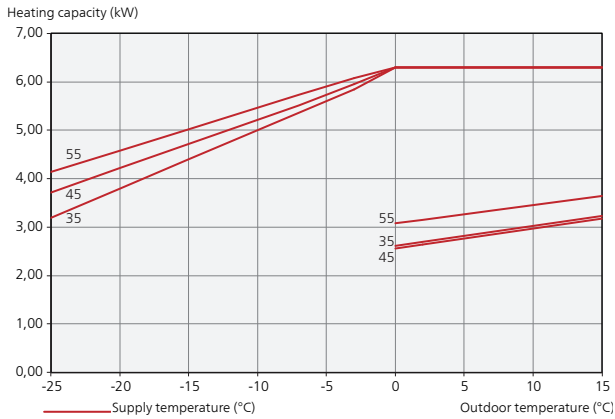

### JÄSPI Inverter Nordic-8 COP

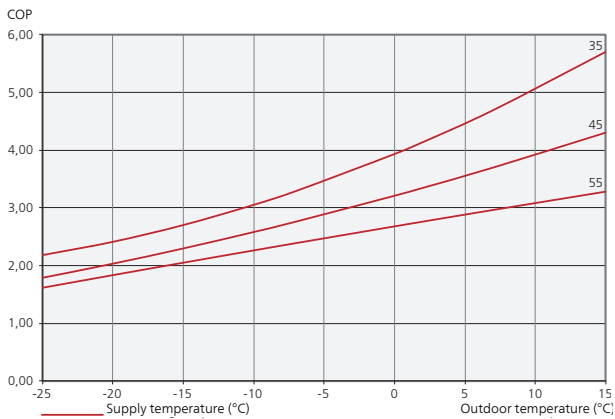

### JÄSPI Inverter Nordic-12

JÄSPI Inverter Nordic-12 max and min heating capacity

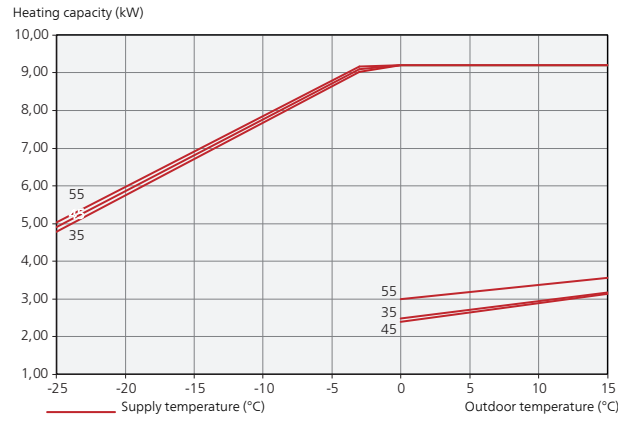

### JÄSPI Inverter Nordic-12 COP

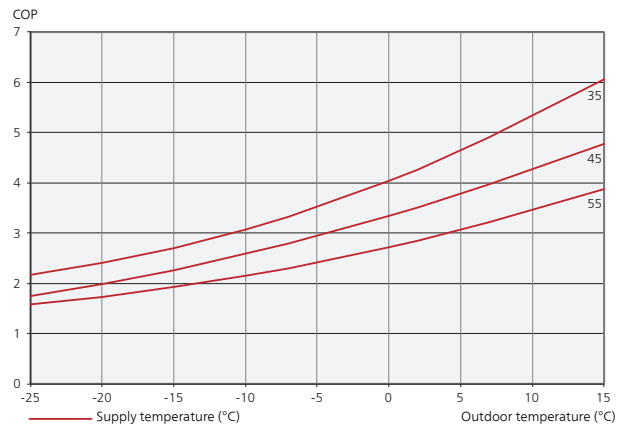

### JÄSPI Inverter Nordic-16

JÄSPI Inverter Nordic-16 max and min heating capacity

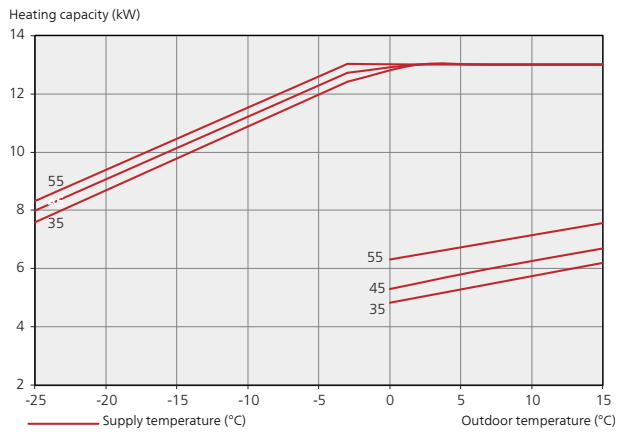

### JÄSPI Inverter Nordic-20

JÄSPI Inverter Nordic-20 max and min heating capacity

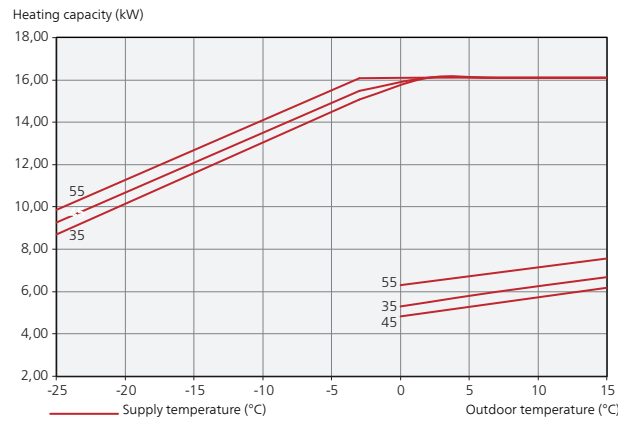

### JÄSPI Inverter Nordic-16 COP

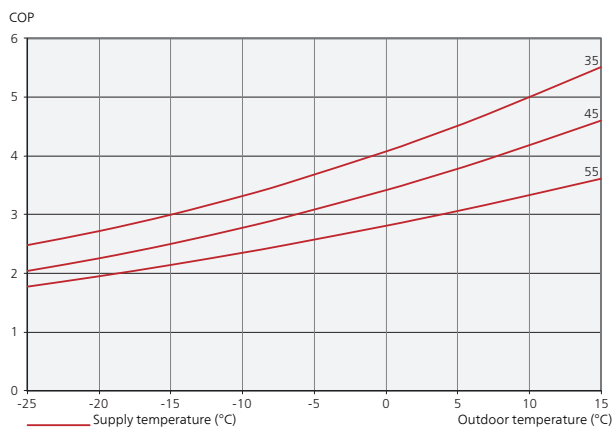

### JÄSPI Inverter Nordic-20 COP

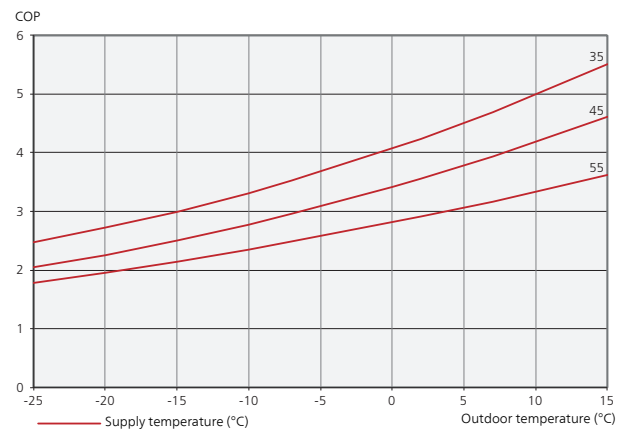

# Cooling

## Output at different supply temperatures (cooling)

### JÄSPI Inverter Nordic-8

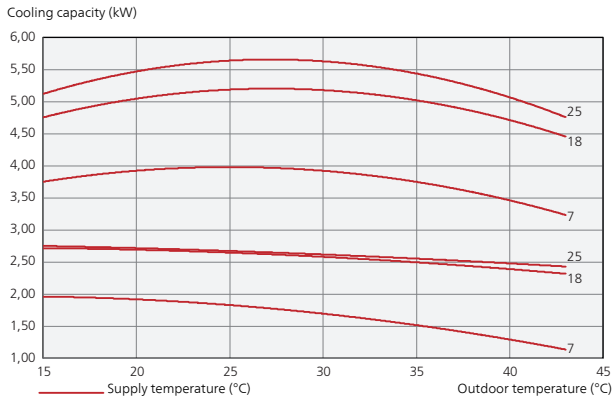

### JÄSPI Inverter Nordic-12

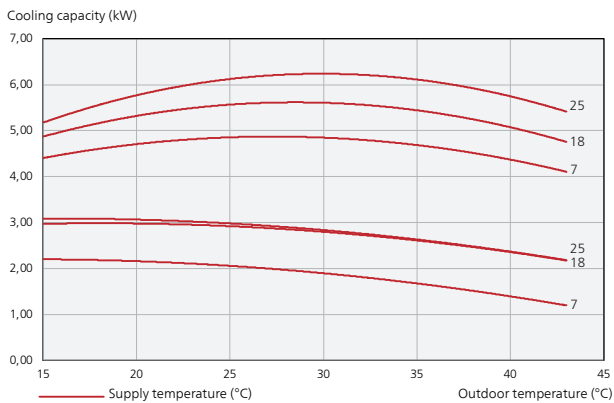

### JÄSPI Inverter Nordic-16

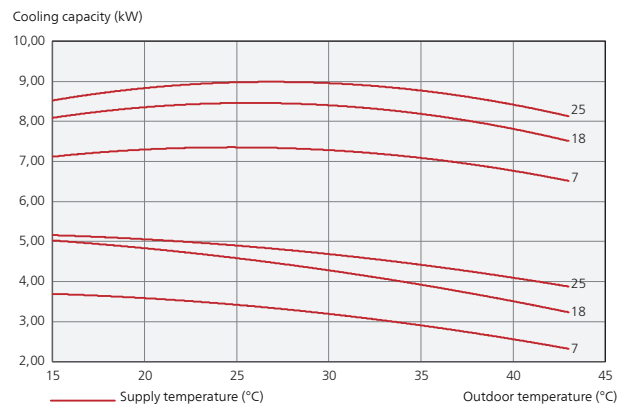

### JÄSPI Inverter Nordic-20

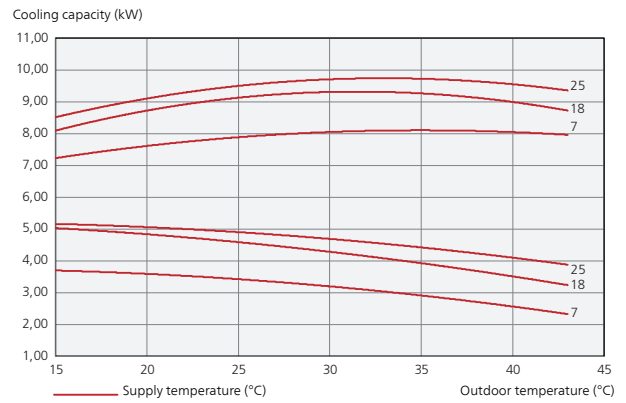

# Energy labelling

## Information sheet

Supplier	Kaukora				
Model	JÄSPI Inverter HPM-8	JÄSPI Inverter HPM-12	Jäspi Inverter HPM-16	JÄSPI Inverter HPM-20	
Model hot water heater	JÄSPI Tehowatti Air	Jäspi Tehowatti AIR	Jäspi Tehowatti AIR	JÄSPI Tehowatti Air	
Temperature application	°C	35 / 55	35 / 55	35 / 55	35 / 55
Declared load profile for water heating		<b>XL</b>	<b>XL</b>	<b>XL</b>	<b>XL</b>
Seasonal space heating energy efficiency class, average climate		<b>A++ / A++</b>	<b>A++ / A++</b>	<b>A++ / A++</b>	<b>A++ / A++</b>
Water heating energy efficiency class, average climate		<b>A</b>	<b>A</b>	<b>A</b>	<b>A</b>
Rated heat output (Pdesignh), average climate	kW	5.9 / 6.3	8.0 / 8.3	11.0 / 12.3	11.0 / 12.3
Annual energy consumption space heating, average climate	kWh	2,544 / 3,472	3,409 / 4,529	4,502 / 6,524	4,502 / 6,524
Annual energy consumption water heating, average climate	kWh	1661	1661	1616	1616
Seasonal space heating energy efficiency, average climate	%	189 / 147	190 / 148	199 / 153	199 / 153
Water heating energy efficiency, average climate	%	101	101	104	104
Sound power level L <sub>WA</sub> indoors	dB	35	35	35	35
Rated heat output (Pdesignh), cold climate	kW	6.8 / 7.4	9.3 / 9.8	13.0 / 14.0	13.0 / 14.0
Rated heat output (Pdesignh), warm climate	kW	5.9 / 6.3	9.2 / 9.2	13.0 / 13.0	13.0 / 13.0
Annual energy consumption space heating, cold climate	kWh	4,182 / 5,524	5,666 / 7,239	7,543 / 9,765	7,543 / 9,765
Annual energy consumption water heating, cold climate	kWh	1895	1895	1758	1758
Annual energy consumption space heating, warm climate	kWh	1,452 / 1,939	2,241 / 2,741	3,153 / 3,867	3,153 / 3,867
Annual energy consumption water heating, warm climate	kWh	1473	1473	1448	1448
Seasonal space heating energy efficiency, cold climate	%	158 / 130	159 / 130	167 / 138	167 / 138
Water heating energy efficiency, cold climate	%	88	88	95	95
Seasonal space heating energy efficiency, warm climate	%	214 / 171	216 / 176	217 / 177	217 / 177
Water heating energy efficiency, warm climate	%	114	114	116	116
Sound power level L <sub>WA</sub> outdoors	dB	53	53	53	53

## Data for energy efficiency of the package

Model	JÄSPI Inverter HPM-8	JÄSPI Inverter HPM-12	Jäspi Inverter HPM-16	JÄSPI Inverter HPM-20	
Model hot water heater	JÄSPI Tehowatti Air	Jäspi Tehowatti AIR	Jäspi Tehowatti AIR	JÄSPI Tehowatti Air	
Temperature application	°C	35 / 55	35 / 55	35 / 55	35 / 55
Controller, class	VI				
Controller, contribution to efficiency	4.0				
Seasonal space heating energy efficiency of the package, average climate	%	193 / 151	194 / 152	203 / 157	203 / 157
Seasonal space heating energy efficiency class of the package, average climate		<b>A+++ / A+++</b>	<b>A+++ / A+++</b>	<b>A+++ / A+++</b>	<b>A+++ / A+++</b>
Seasonal space heating energy efficiency of the package, cold climate	%	162 / 134	163 / 134	171 / 142	171 / 142
Seasonal space heating energy efficiency of the package, warm climate	%	218 / 175	220 / 180	221 / 181	221 / 181

The reported efficiency of the package also takes the controller into account. If an external supplementary boiler or solar heating is added to the package, the overall efficiency of the package should be recalculated.

## Technical documentation

Model				JÄSPI Inverter HPM-8							
Model hot water heater				JÄSPI Tehowatti Air							
Type of heat pump				<input checked="" type="checkbox"/> Air-water <input type="checkbox"/> Exhaust-water <input type="checkbox"/> Brine-water <input type="checkbox"/> Water-water							
Low-temperature heat pump				<input type="checkbox"/> Yes <input checked="" type="checkbox"/> No							
Integrated immersion heater for additional heat				<input checked="" type="checkbox"/> Yes <input type="checkbox"/> No							
Heat pump combination heater				<input checked="" type="checkbox"/> Yes <input type="checkbox"/> No							
Climate				<input checked="" type="checkbox"/> Average <input type="checkbox"/> Cold <input type="checkbox"/> Warm							
Temperature application				<input checked="" type="checkbox"/> Average (55 °C) <input type="checkbox"/> Low (35 °C)							
Applied standards				EN14825 / EN14511 / EN16147 / EN12102							
<b>Rated heat output</b>		Prated	6,3	kW	<b>Seasonal space heating energy efficiency</b>		$\eta_s$	147	%		
<i>Declared capacity for space heating at part load and at outdoor temperature <math>T_j</math></i>					<i>Declared coefficient of performance for space heating at part load and at outdoor temperature <math>T_j</math></i>						
$T_j = -7\text{ °C}$	Pdh	5.5	kW	$T_j = -7\text{ °C}$	COPd	2.48	-				
$T_j = +2\text{ °C}$	Pdh	4.1	kW	$T_j = +2\text{ °C}$	COPd	3.80	-				
$T_j = +7\text{ °C}$	Pdh	2.9	kW	$T_j = +7\text{ °C}$	COPd	4.45	-				
$T_j = +12\text{ °C}$	Pdh	3.3	kW	$T_j = +12\text{ °C}$	COPd	5.26	-				
$T_j = \text{biv}$	Pdh	5.5	kW	$T_j = \text{biv}$	COPd	2.48	-				
$T_j = \text{TOL}$	Pdh	5.7	kW	$T_j = \text{TOL}$	COPd	2.34	-				
$T_j = -15\text{ °C}$ (if TOL < -20 °C)	Pdh		kW	$T_j = -15\text{ °C}$ (if TOL < -20 °C)	COPd		-				
Bivalent temperature				$T_{\text{biv}}$	-7	°C	Min. outdoor air temperature		TOL	-10	°C
Cycling interval capacity				Pcych		kW	Cycling interval efficiency		COPcyc		-
Degradation coefficient				Cdh	0.99	-	Max supply temperature		WTOL	65	°C
<i>Power consumption in modes other than active mode</i>					<i>Additional heat</i>						
Off mode		P <sub>OFF</sub>	0.025	kW	Rated heat output		P <sub>sup</sub>	0.0	kW		
Thermostat-off mode		P <sub>TO</sub>	0.01	kW							
Standby mode		P <sub>SB</sub>	0.025	kW	Type of energy input		Electric				
Crankcase heater mode		P <sub>CK</sub>	0.037	kW							
<i>Other items</i>											
Capacity control		Variable			Rated airflow (air-water)			2,400	m <sup>3</sup> /h		
Sound power level, indoors/outdoors		L <sub>WA</sub>	35 / 53	dB	Nominal heating medium flow				m <sup>3</sup> /h		
Annual energy consumption		Q <sub>HE</sub>	3,472	kWh	Brine flow brine-water or water-water heat pumps				m <sup>3</sup> /h		
<i>For heat pump combination heater</i>											
<b>Declared load profile for water heating</b>				XL		<b>Water heating energy efficiency</b>		$\eta_{\text{wh}}$	101	%	
Daily energy consumption		Q <sub>elec</sub>	7.56	kWh	Daily fuel consumption		Q <sub>fuel</sub>		kWh		
Annual energy consumption		AEC	1,661	kWh	Annual fuel consumption		AFC		GJ		

Model		JÄSPI Inverter HPM-12					
Model hot water heater		Jäspi Tehowatti AIR					
Type of heat pump	<input checked="" type="checkbox"/> Air-water <input type="checkbox"/> Exhaust-water <input type="checkbox"/> Brine-water <input type="checkbox"/> Water-water						
Low-temperature heat pump	<input type="checkbox"/> Yes <input checked="" type="checkbox"/> No						
Integrated immersion heater for additional heat	<input checked="" type="checkbox"/> Yes <input type="checkbox"/> No						
Heat pump combination heater	<input checked="" type="checkbox"/> Yes <input type="checkbox"/> No						
Climate	<input checked="" type="checkbox"/> Average <input type="checkbox"/> Cold <input type="checkbox"/> Warm						
Temperature application	<input checked="" type="checkbox"/> Average (55 °C) <input type="checkbox"/> Low (35 °C)						
Applied standards	EN14825 / EN14511 / EN16147 / EN12102						
<b>Rated heat output</b>	Prated	8,3	kW	<b>Seasonal space heating energy efficiency</b>	$\eta_s$	148	%
<i>Declared capacity for space heating at part load and at outdoor temperature <math>T_j</math></i>				<i>Declared coefficient of performance for space heating at part load and at outdoor temperature <math>T_j</math></i>			
$T_j = -7\text{ °C}$	Pdh	7.3	kW	$T_j = -7\text{ °C}$	COPd	2.39	-
$T_j = +2\text{ °C}$	Pdh	4.7	kW	$T_j = +2\text{ °C}$	COPd	3.85	-
$T_j = +7\text{ °C}$	Pdh	2.9	kW	$T_j = +7\text{ °C}$	COPd	4.48	-
$T_j = +12\text{ °C}$	Pdh	3.3	kW	$T_j = +12\text{ °C}$	COPd	5.30	-
$T_j = \text{biv}$	Pdh	7.3	kW	$T_j = \text{biv}$	COPd	2.39	-
$T_j = \text{TOL}$	Pdh	7.8	kW	$T_j = \text{TOL}$	COPd	2.28	-
$T_j = -15\text{ °C}$ (if TOL < -20 °C)	Pdh		kW	$T_j = -15\text{ °C}$ (if TOL < -20 °C)	COPd		-
Bivalent temperature	$T_{\text{biv}}$	-7	°C	Min. outdoor air temperature	TOL	-10	°C
Cycling interval capacity	P <sub>psych</sub>		kW	Cycling interval efficiency	COP <sub>psych</sub>		-
Degradation coefficient	Cdh	0.99	-	Max supply temperature	WTOL	65	°C
<i>Power consumption in modes other than active mode</i>				<i>Additional heat</i>			
Off mode	P <sub>OFF</sub>	0.025	kW	Rated heat output	P <sub>sup</sub>	0.5	kW
Thermostat-off mode	P <sub>TO</sub>	0.007	kW				
Standby mode	P <sub>SB</sub>	0.025	kW	Type of energy input	Electric		
Crankcase heater mode	P <sub>CK</sub>	0.037	kW				
<i>Other items</i>							
Capacity control	Variable			Rated airflow (air-water)		3,400	m <sup>3</sup> /h
Sound power level, indoors/outdoors	L <sub>WA</sub>	35 / 53	dB	Nominal heating medium flow			m <sup>3</sup> /h
Annual energy consumption	Q <sub>HE</sub>	4,529	kWh	Brine flow brine-water or water-water heat pumps			m <sup>3</sup> /h
<i>For heat pump combination heater</i>							
<b>Declared load profile for water heating</b>				<b>Water heating energy efficiency</b>			
Daily energy consumption	Q <sub>elec</sub>	7.56	kWh	Daily fuel consumption	$\eta_{\text{wh}}$	101	%
Annual energy consumption	AEC	1,661	kWh	Annual fuel consumption	AFC		GJ



Model		Jäspi Inverter HPM-16							
Model hot water heater		Jäspi Tehowatti AIR							
Type of heat pump		<input checked="" type="checkbox"/> Air-water <input type="checkbox"/> Exhaust-water <input type="checkbox"/> Brine-water <input type="checkbox"/> Water-water							
Low-temperature heat pump		<input type="checkbox"/> Yes <input checked="" type="checkbox"/> No							
Integrated immersion heater for additional heat		<input checked="" type="checkbox"/> Yes <input type="checkbox"/> No							
Heat pump combination heater		<input checked="" type="checkbox"/> Yes <input type="checkbox"/> No							
Climate		<input checked="" type="checkbox"/> Average <input type="checkbox"/> Cold <input type="checkbox"/> Warm							
Temperature application		<input checked="" type="checkbox"/> Average (55 °C) <input type="checkbox"/> Low (35 °C)							
Applied standards		EN14825 / EN14511 / EN16147 / EN12102							
<b>Rated heat output</b>		Prated	12,3	kW	<b>Seasonal space heating energy efficiency</b>		$\eta_s$	153	%
<i>Declared capacity for space heating at part load and at outdoor temperature <math>T_j</math></i>				<i>Declared coefficient of performance for space heating at part load and at outdoor temperature <math>T_j</math></i>					
$T_j = -7\text{ °C}$	Pdh	10.9	kW	$T_j = -7\text{ °C}$	COPd	2.48	-		
$T_j = +2\text{ °C}$	Pdh	6.7	kW	$T_j = +2\text{ °C}$	COPd	3.96	-		
$T_j = +7\text{ °C}$	Pdh	5.9	kW	$T_j = +7\text{ °C}$	COPd	4.67	-		
$T_j = +12\text{ °C}$	Pdh	6.5	kW	$T_j = +12\text{ °C}$	COPd	5.67	-		
$T_j = \text{biv}$	Pdh	10.9	kW	$T_j = \text{biv}$	COPd	2.48	-		
$T_j = \text{TOL}$	Pdh	11.6	kW	$T_j = \text{TOL}$	COPd	2.40	-		
$T_j = -15\text{ °C}$ (if TOL < -20 °C)	Pdh		kW	$T_j = -15\text{ °C}$ (if TOL < -20 °C)	COPd		-		
Bivalent temperature	$T_{\text{biv}}$	-7	°C	Min. outdoor air temperature	TOL	-10	°C		
Cycling interval capacity	P <sub>psych</sub>		kW	Cycling interval efficiency	COP <sub>psych</sub>		-		
Degradation coefficient	Cdh	0.99	-	Max supply temperature	WTOL	65	°C		
<i>Power consumption in modes other than active mode</i>				<i>Additional heat</i>					
Off mode	P <sub>OFF</sub>	0.025	kW	Rated heat output		P <sub>sup</sub>	0.7	kW	
Thermostat-off mode	P <sub>TO</sub>	0.007	kW						
Standby mode	P <sub>SB</sub>	0.025	kW	Type of energy input		Electric			
Crankcase heater mode	P <sub>CK</sub>	0.037	kW						
<i>Other items</i>									
Capacity control	Variable			Rated airflow (air-water)			4,150	m <sup>3</sup> /h	
Sound power level, indoors/outdoors	L <sub>WA</sub>	35 / 53	dB	Nominal heating medium flow				m <sup>3</sup> /h	
Annual energy consumption	Q <sub>HE</sub>	6,524	kWh	Brine flow brine-water or water-water heat pumps				m <sup>3</sup> /h	
<i>For heat pump combination heater</i>									
<b>Declared load profile for water heating</b>		XL		<b>Water heating energy efficiency</b>		$\eta_{\text{wh}}$	104	%	
Daily energy consumption	Q <sub>elec</sub>	7.36	kWh	Daily fuel consumption		Q <sub>fuel</sub>		kWh	
Annual energy consumption	AEC	1,616	kWh	Annual fuel consumption		AFC		GJ	

Model		JÄSPI Inverter HPM-20						
Model hot water heater		JÄSPI Tehowatti Air						
Type of heat pump	<input checked="" type="checkbox"/> Air-water <input type="checkbox"/> Exhaust-water <input type="checkbox"/> Brine-water <input type="checkbox"/> Water-water							
Low-temperature heat pump	<input type="checkbox"/> Yes <input checked="" type="checkbox"/> No							
Integrated immersion heater for additional heat	<input checked="" type="checkbox"/> Yes <input type="checkbox"/> No							
Heat pump combination heater	<input checked="" type="checkbox"/> Yes <input type="checkbox"/> No							
Climate	<input checked="" type="checkbox"/> Average <input type="checkbox"/> Cold <input type="checkbox"/> Warm							
Temperature application	<input checked="" type="checkbox"/> Average (55 °C) <input type="checkbox"/> Low (35 °C)							
Applied standards	EN14825 / EN14511 / EN16147 / EN12102							
<b>Rated heat output</b>	Prated	12,3	kW	<b>Seasonal space heating energy efficiency</b>	$\eta_s$	153	%	
<i>Declared capacity for space heating at part load and at outdoor temperature <math>T_j</math></i>				<i>Declared coefficient of performance for space heating at part load and at outdoor temperature <math>T_j</math></i>				
$T_j = -7\text{ °C}$	Pdh	10.9	kW	$T_j = -7\text{ °C}$	COPd	2.48	-	
$T_j = +2\text{ °C}$	Pdh	6.7	kW	$T_j = +2\text{ °C}$	COPd	3.96	-	
$T_j = +7\text{ °C}$	Pdh	5.9	kW	$T_j = +7\text{ °C}$	COPd	4.67	-	
$T_j = +12\text{ °C}$	Pdh	6.5	kW	$T_j = +12\text{ °C}$	COPd	5.67	-	
$T_j = \text{biv}$	Pdh	10.9	kW	$T_j = \text{biv}$	COPd	2.48	-	
$T_j = \text{TOL}$	Pdh	11.6	kW	$T_j = \text{TOL}$	COPd	2.40	-	
$T_j = -15\text{ °C}$ (if TOL < -20 °C)	Pdh		kW	$T_j = -15\text{ °C}$ (if TOL < -20 °C)	COPd		-	
Bivalent temperature	$T_{\text{biv}}$	-7	°C	Min. outdoor air temperature	TOL	-10	°C	
Cycling interval capacity	P <sub>psych</sub>		kW	Cycling interval efficiency	COP <sub>psych</sub>		-	
Degradation coefficient	Cdh	0.99	-	Max supply temperature	WTOL	65	°C	
<i>Power consumption in modes other than active mode</i>				<i>Additional heat</i>				
Off mode	P <sub>OFF</sub>	0.025	kW	Rated heat output	P <sub>sup</sub>	0.7	kW	
Thermostat-off mode	P <sub>TO</sub>	0.007	kW					
Standby mode	P <sub>SB</sub>	0.025	kW	Type of energy input	Electric			
Crankcase heater mode	P <sub>CK</sub>	0.037	kW					
<i>Other items</i>								
Capacity control	Variable			Rated airflow (air-water)		4,150	m <sup>3</sup> /h	
Sound power level, indoors/outdoors	L <sub>WA</sub>	35 / 53	dB	Nominal heating medium flow			m <sup>3</sup> /h	
Annual energy consumption	Q <sub>HE</sub>	6,524	kWh	Brine flow brine-water or water-water heat pumps			m <sup>3</sup> /h	
<i>For heat pump combination heater</i>								
<b>Declared load profile for water heating</b>		XL		<b>Water heating energy efficiency</b>		$\eta_{\text{wh}}$	104	%
Daily energy consumption	Q <sub>elec</sub>	7.36	kWh	Daily fuel consumption	Q <sub>fuel</sub>		kWh	
Annual energy consumption	AEC	1,616	kWh	Annual fuel consumption	AFC		GJ	

# Electrical circuit diagram

## 1x230V

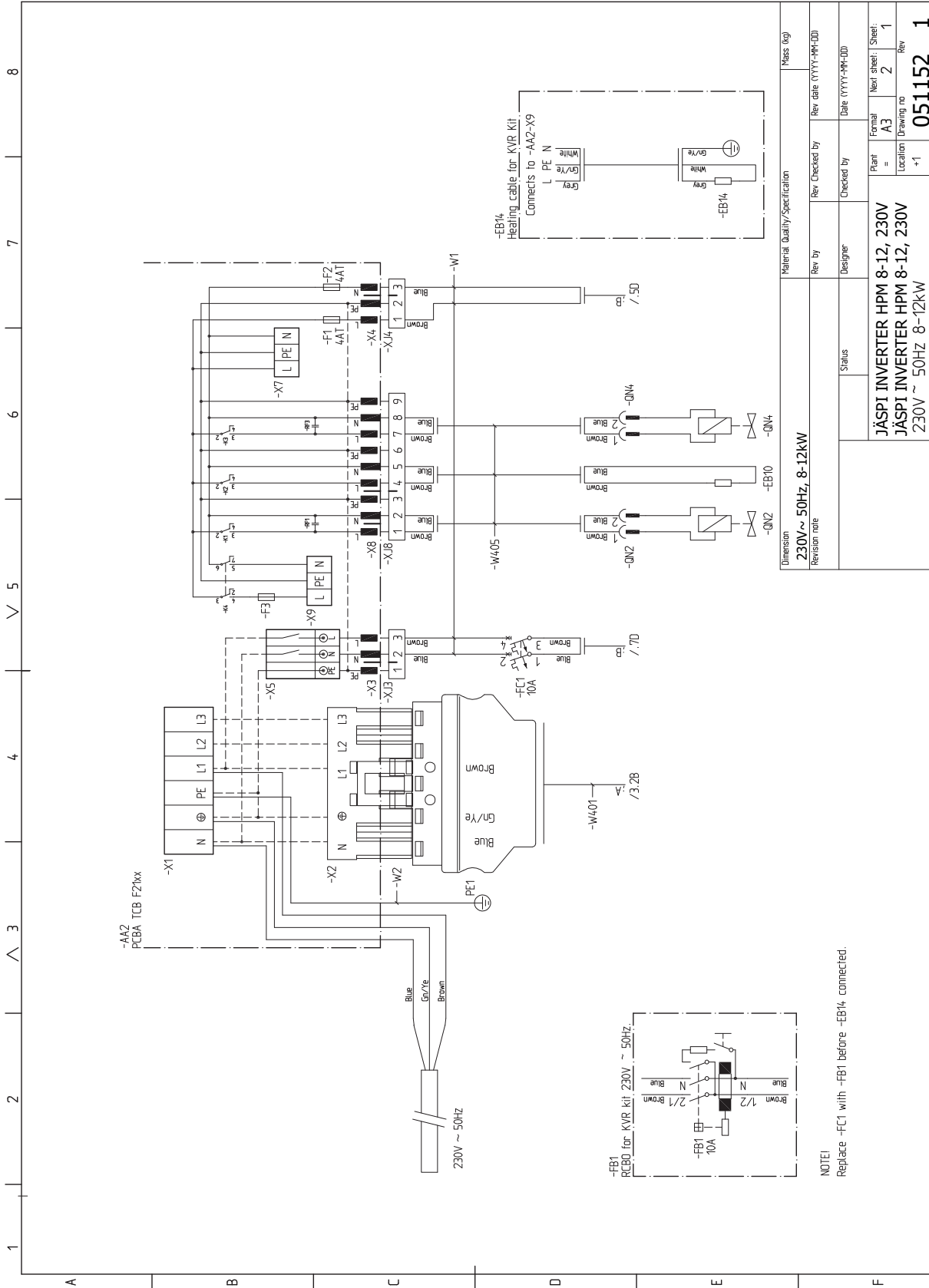

Material Quality/Specification		Mass (kg)	
Dimension	230V ~ 50Hz, 8-12kW	Rev. by	Rev. date (YYYY-MM-DD)
Revision note		Checked by	Checked by
Status		Designer	Date (YYYY-MM-DD)
JÄSPI INVERTER HPM 8-12, 230V		Plant =	Formal
JÄSPI INVERTER HPM 8-12, 230V		Location	Next sheet / Sheet
230V ~ 50Hz 8-12kW		Drawing no	Rev
		+1	051152
		1	1

Based on: DSN000594-2

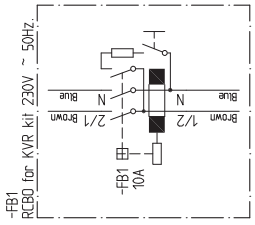
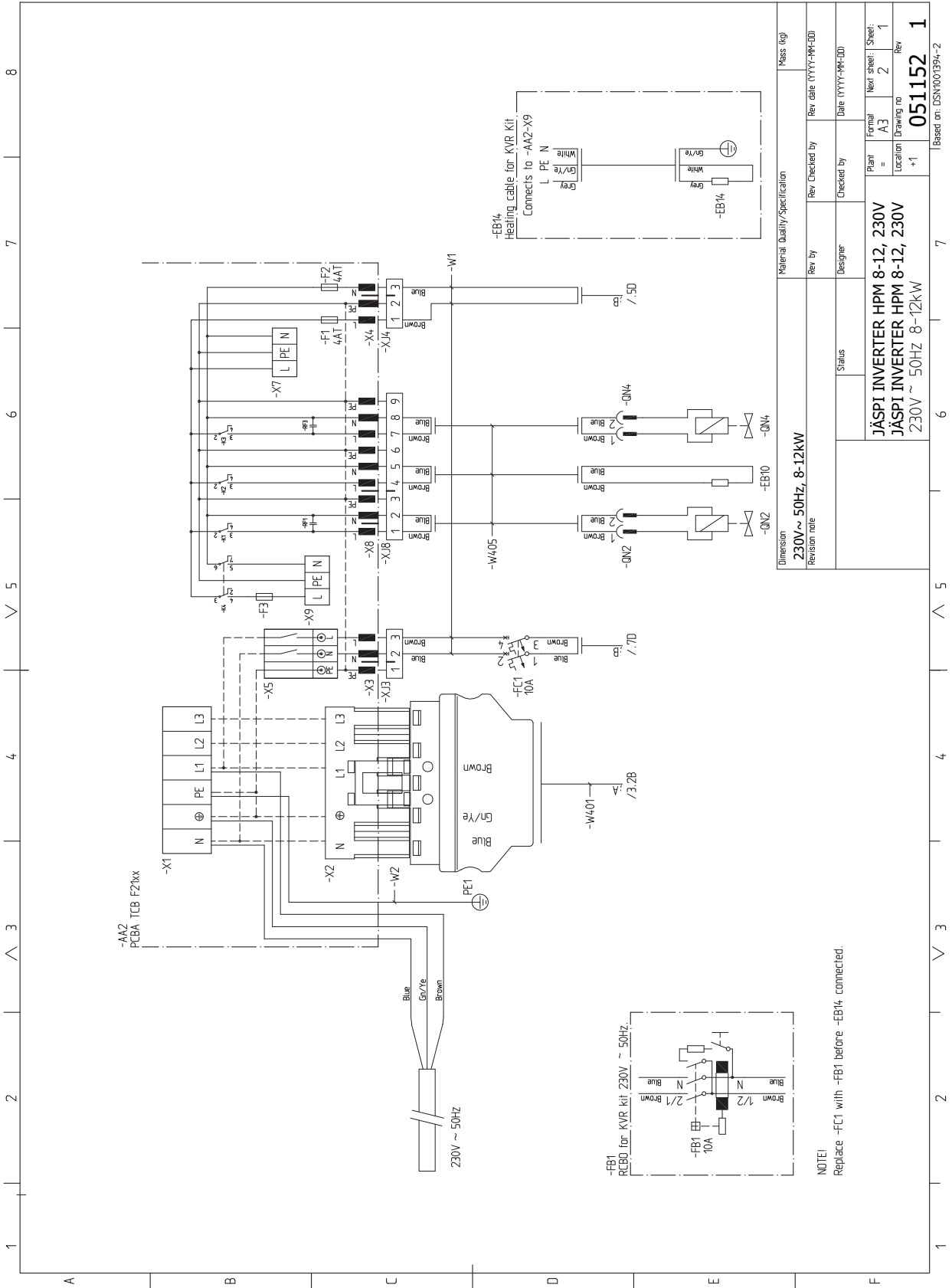

NOTE!  
Replace -FC1 with -FB1 before -EB14 connected.

Material Quality/Specification		Mass (kg)	
Dimension	230V ~ 50Hz, 8-12kW	Rev. by	Rev. date (YYYY-MM-DD)
Revision note		Designer	Checked by
		Status	Checked by
		Plant	Formal sheet / Sheet:
		A3	2 / 1
		Location	Drawing no
		+1	051152
		Rev	1
			1

JÄSPI INVERTER HPM 8-12, 230V  
JÄSPI INVERTER HPM 8-12, 230V  
230V ~ 50Hz 8-12kW

Based on: DSN001394-2

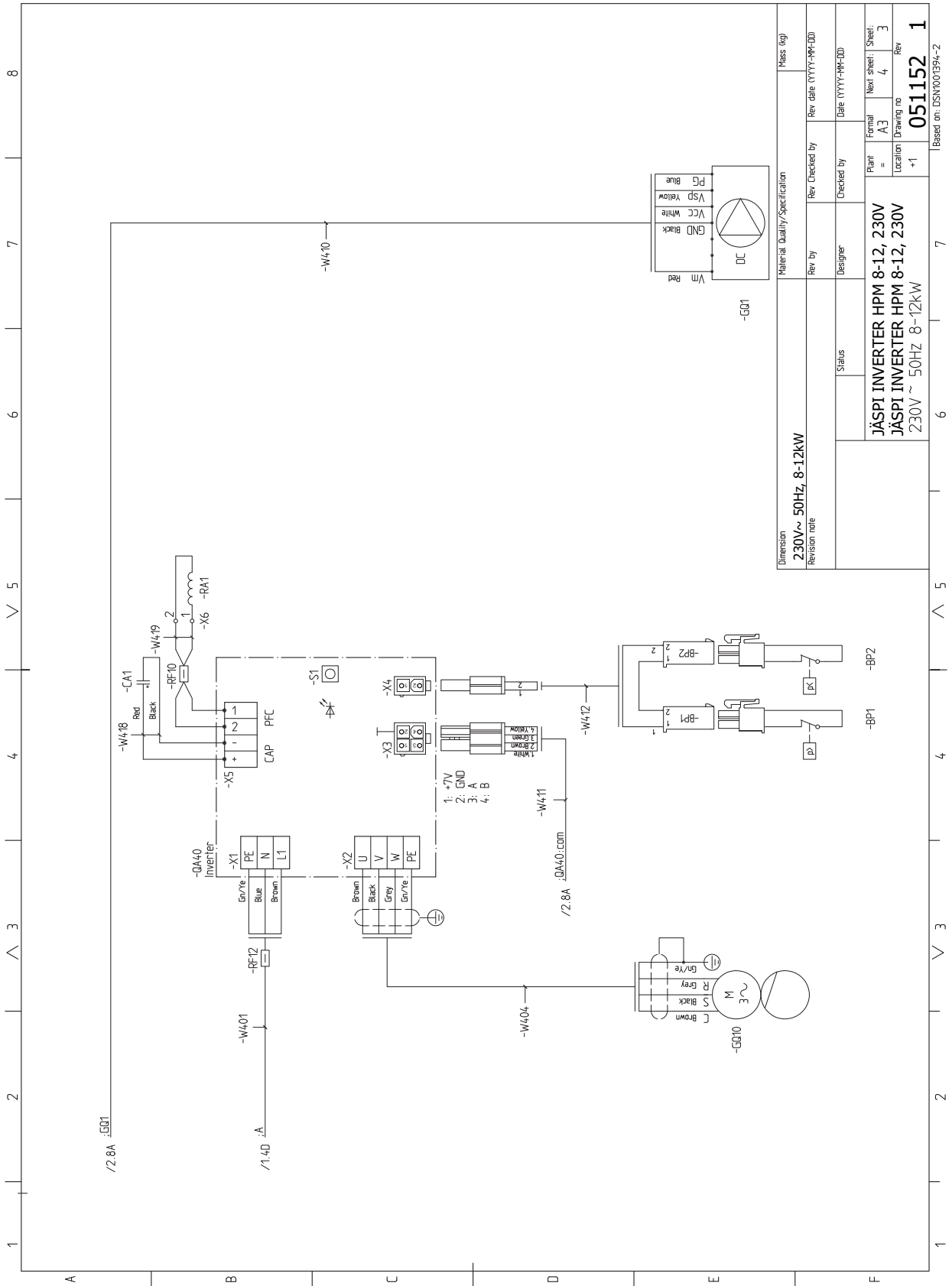

Dimension		Material Quality/Specification		Mass (kg)	
2.30V~50Hz, 8-12kW					
Revision note		Rev. by	Rev. Checked by	Rev. date (YYYY-MM-DD)	
		Designer	Checked by	Date (YYYY-MM-DD)	
		Status	Plant	Formal	Next sheet
			=	A3	4
			Location	Drawing no	Rev
				+1	051152
					1

JÄSPI INVERTER HPM 8-12, 230V  
 JÄSPI INVERTER HPM 8-12, 230V  
 230V ~ 50Hz 8-12kW

Based on: DSN0001394-2

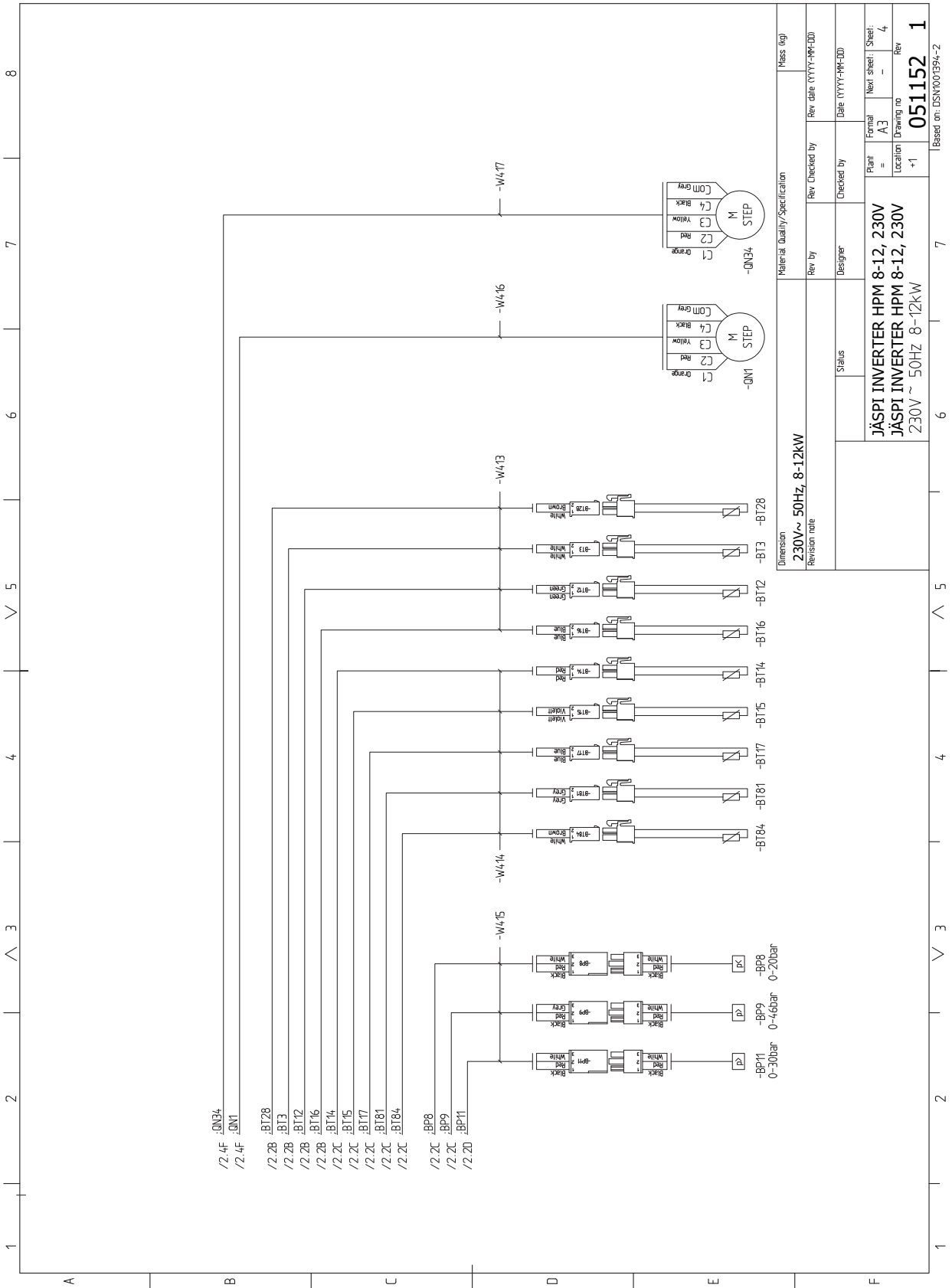

# 3x400V

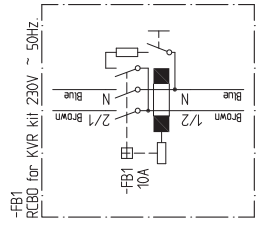
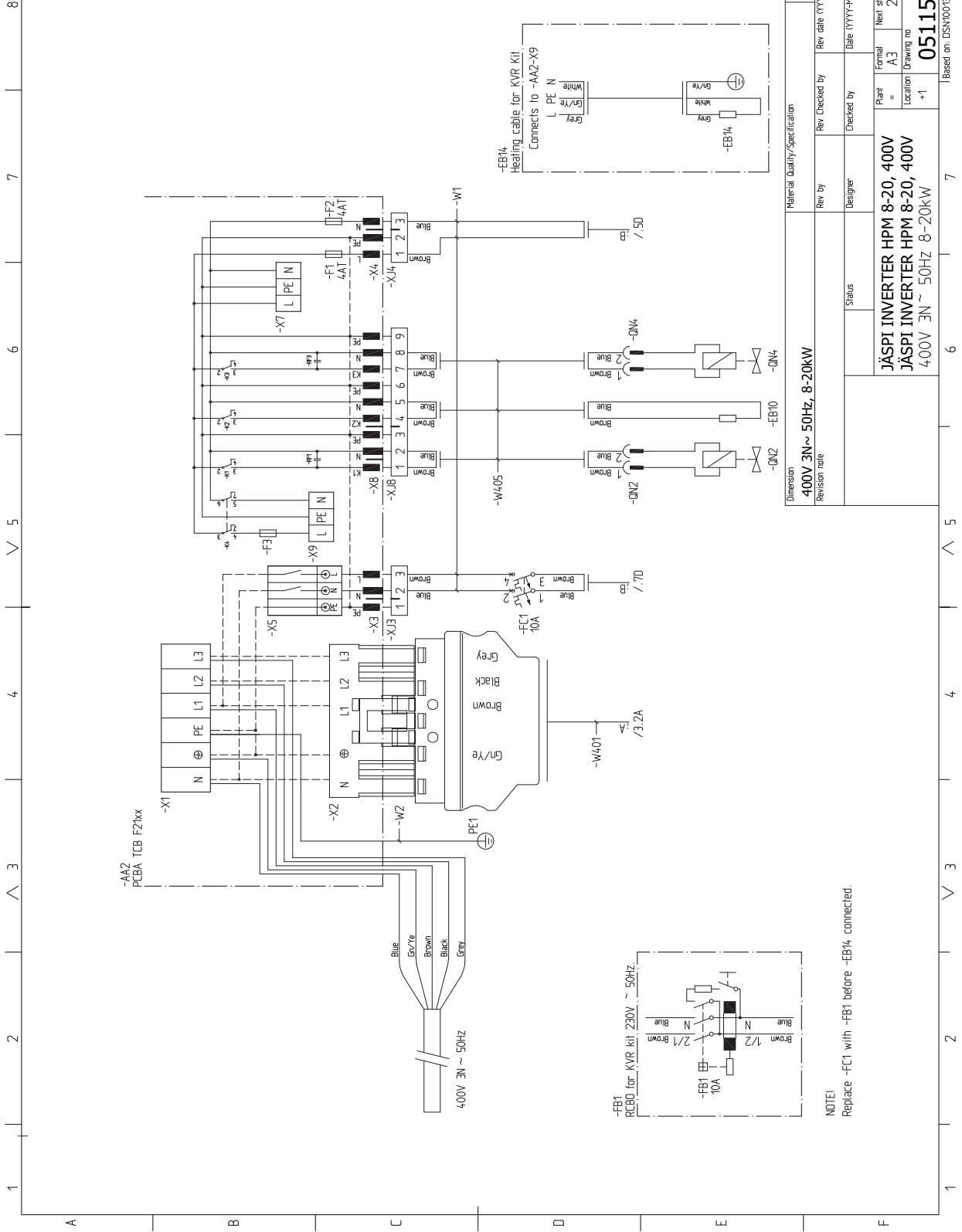

NOTE!  
Replace -FB1 with -FB1 before -EB14 connected.

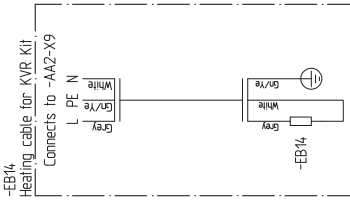

Material Quality/Specification		Mass (kg)	
Dimension	400V 3N~50Hz, 8-20kW	Rev. Checked by	Rev. date (YY-MM-DD)
Revision note		Designer	Checked by
Status		Formal	Next sheet
JÄSPI INVERTER HPM 8-20, 400V		Plan =	A3
JÄSPI INVERTER HPM 8-20, 400V		Location	Drawing no
400V 3N~50Hz 8-20kW		+1	051153
		Rev	1
			1
			1

Based on: DSN001395-2

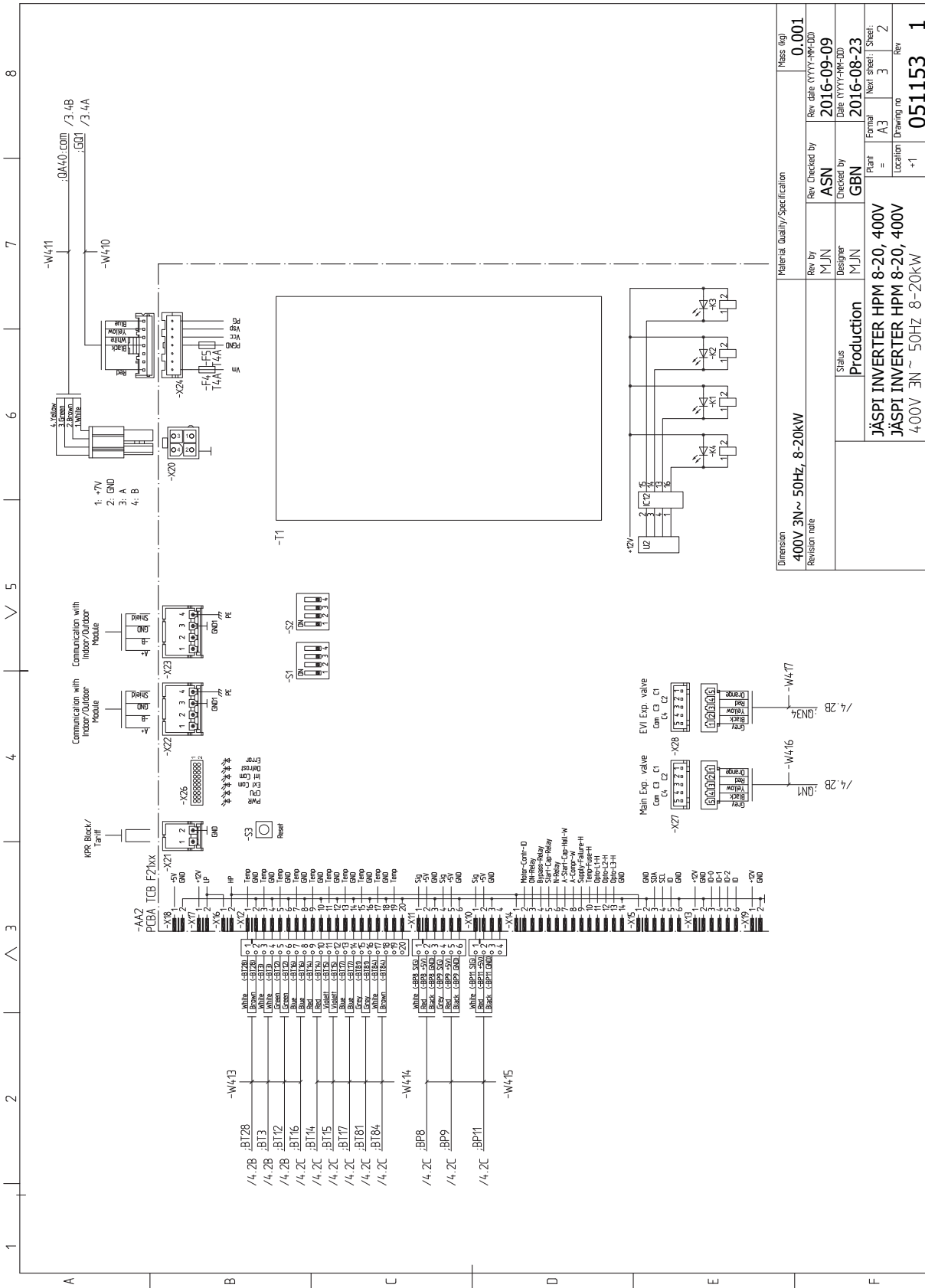



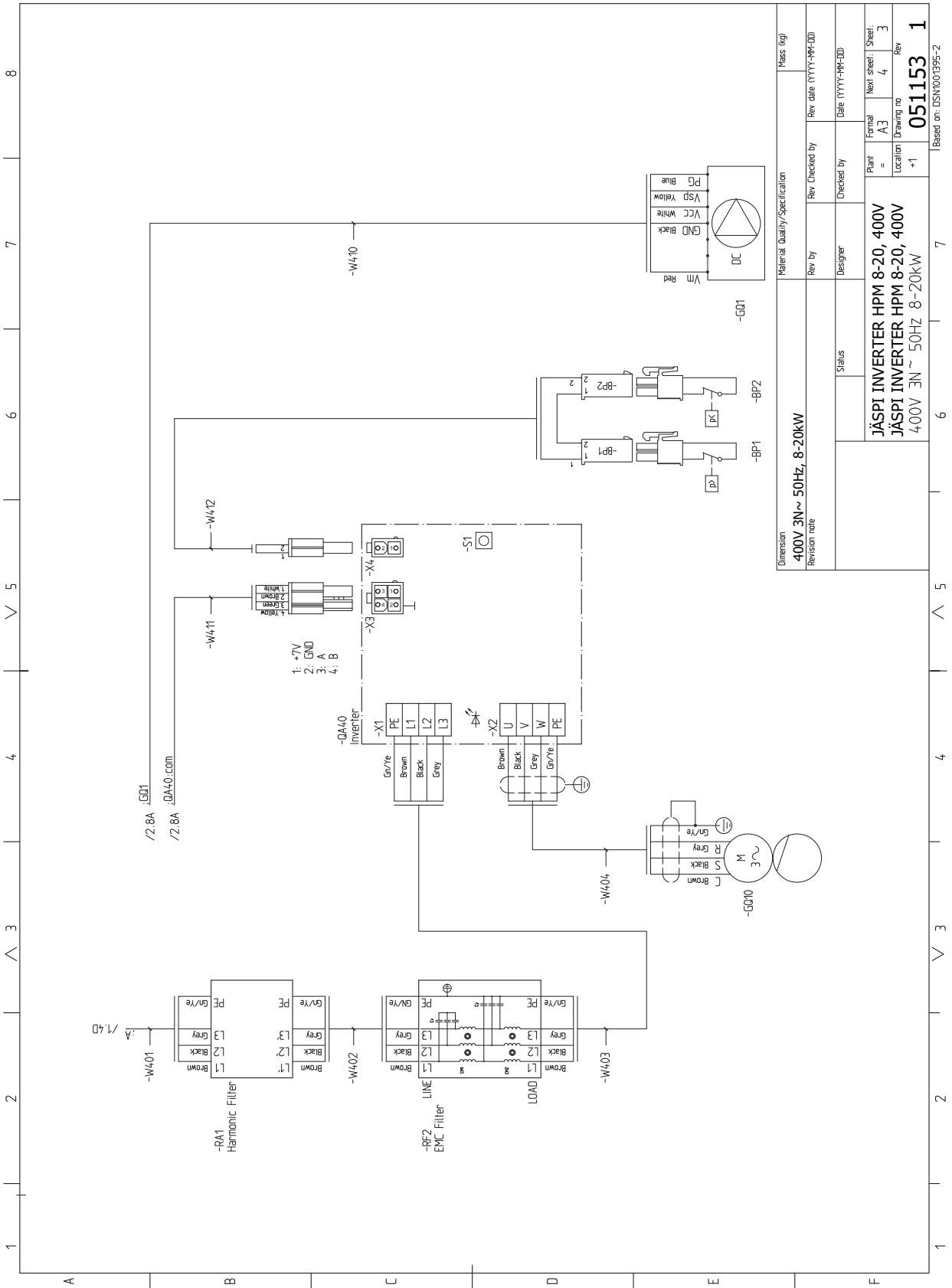

Material Quality/Specification		Mass (kg)	
Dimension	400V 3N~ 50Hz, 8-20kW	Rev. Checked by	Rev. date (YYYY-MM-DD)
Revision note		Designer	Checked by
		Status	
JÄSPI INVERTER HPM 8-20, 400V		Plan nr	Formal
JÄSPI INVERTER HPM 8-20, 400V		Location	Next sheet
400V 3N~ 50Hz 8-20kW		Drawing no	Sheet
		+1	3
			4
			1
Based on: DSN0001395-2			

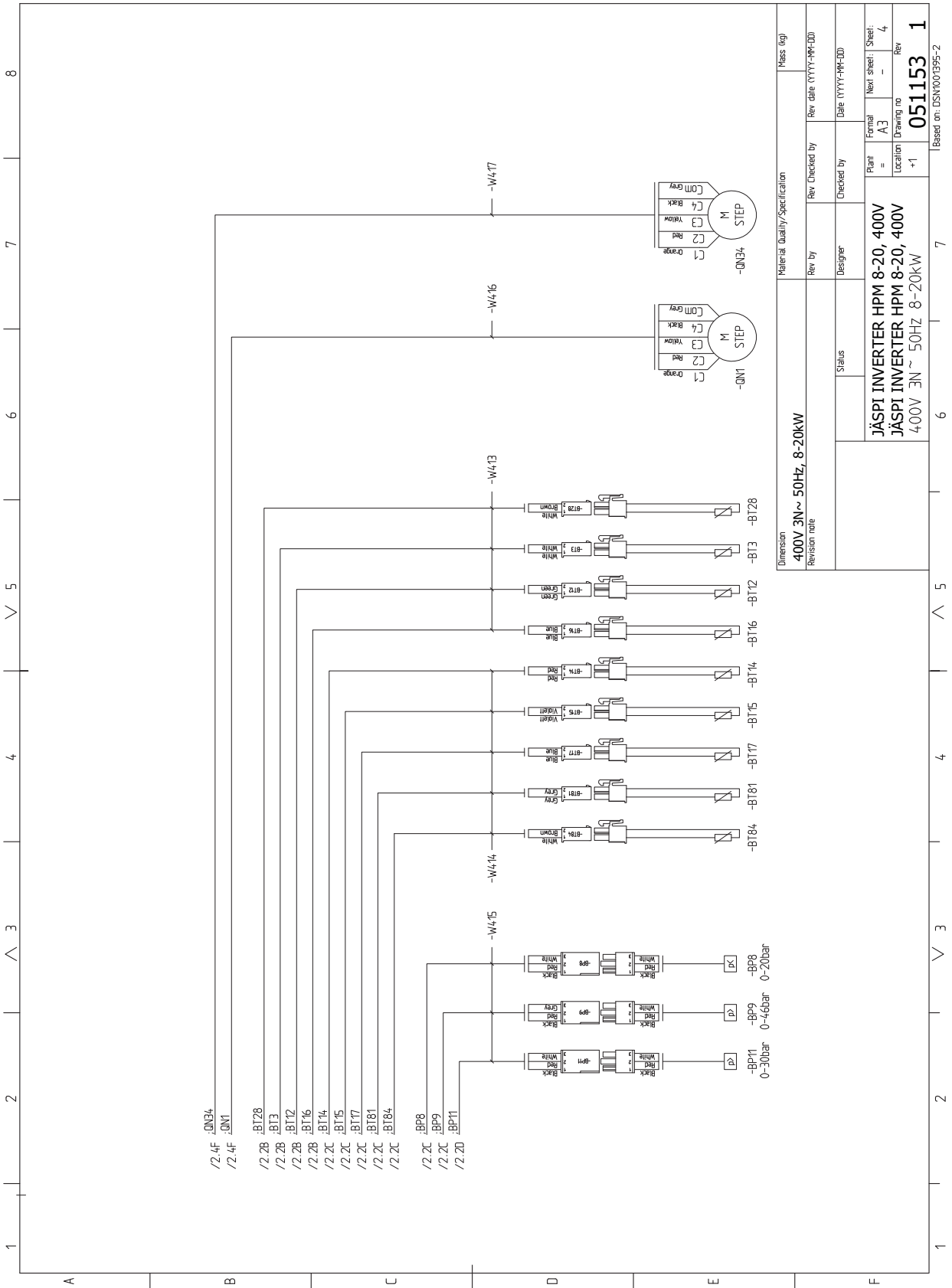

# 12 Item register

## Item register

### A

Accessories, 42  
Addressing via multi-heat pump operation, 24  
Adjustment, charge flow, 33  
Alarm list, 40  
Assembly, 9

### B

Balance temperature, 4

### C

Charge pump, 20  
Commissioning and adjusting, 32  
    Adjustment, charge flow, 33  
    Balance temperature, 4  
    Compressor heater, 4  
    Filling and venting the heating medium system, 32  
    Preparations, 32  
    Readjusting, heating medium side, 32  
    Start-up and inspection, 32  
Communication, 28  
Compressor heater, 4  
Connecting accessories, 31  
Connecting external control voltage, 26  
Connections, 25  
    Connecting external control voltage, 26  
Control, 34  
    Control - Introduction, 34  
Control conditions, 35  
Control conditions defrosting, 35  
Control - Heat pump EB101, 36  
Control - Introduction, 34  
    Control conditions, 35  
    Control conditions defrosting, 35  
    Control - Heat pump EB101, 36  
    General, 34  
    LED status, 34  
    Master control, 34

### D

Delivery and handling, 9  
    Assembly, 9  
    Installation area, 13  
    Removing the side cover, 14  
    Supplied components, 13  
    Transport and storage, 9  
Dimensions and setting-out coordinates, 43  
Disturbances in comfort, 37  
    Troubleshooting, 37

### E

Electrical cabinet, 19  
Electrical circuit diagram, 59  
Electrical connections, 22  
    Addressing via multi-heat pump operation, 24  
    Connecting accessories, 31  
    Connections, 25  
    General, 22  
    Optional connections, 28  
    Power connection, 25  
Energy labelling, 54  
    Data for energy efficiency of the package, 54  
    Information sheet, 54  
    Technical documentation, 55

### F

Filling and venting the heating medium system, 32

### I

Important information, 4  
    Recovery, 4  
    Safety information, 4  
Inspection of the installation, 8  
Installation area, 13

### L

LED status, 34

### M

Marking, 4  
Master control, 34

### O

Optional connections, 28  
    Communication, 28

### P

Pipe connections, 20  
    Charge pump, 20  
    General, 20  
    Pipe coupling heating medium circuit, 20  
    Pressure drop, heating medium side, 20  
    Water volumes, 20  
Pipe coupling heating medium circuit, 20  
Power connection, 25  
Preparations, 32  
Pressure drop, heating medium side, 20

### R

Readjusting, heating medium side, 32  
Removing the side cover, 14

### S

Safety information, 4  
    Inspection of the installation, 8  
    Marking, 4  
    Safety precautions, 6  
    Serial number, 4  
    Symbols, 4  
Safety precautions, 6  
Sensor placement, 38  
Serial number, 4  
Sound pressure levels, 44  
Start-up and inspection, 32  
Supplied components, 13  
Symbols, 4

### T

Technical data, 43  
    Dimensions and setting-out coordinates, 43  
    Electrical circuit diagram, 59  
    Sound pressure levels, 44  
    Technical Data, 45  
Technical Data, 45  
The heat pump design, 15  
    Component list electrical cabinet, 19  
    Component location electrical cabinet, 19  
    Component locations, 15  
    List of components, 15, 18  
Transport and storage, 9  
Troubleshooting, 37  
    Sensor placement, 38









Kaukora Oy  
PL 21, Tuotekatu 11  
212 01 Raisio  
+358 2 437 4600  
E-mail: kaukora@kaukora  
www.kaukora.fi



331841